

APS75 T4F Underground Pulling Trailer



Important Safety Notice

Read and understand all procedures and safety instructions before using a Condux Underground Pulling Trailers. Observe all safety information on this page and note specific safety requirements as explained by procedures in this manual. Failure to follow these instructions could result in serious personal injury or death.

ADVERTENCIA:

Favor de leer y comprender todas las instrucciones de operación y seguridad antes de usar la máquina. Si Ud. no comprende las instrucciones favor de consultarle a su jefe.



Save this user's guide for future reference.

COMMUNICATIONS WITH THE MANUFACTURER:

For information related to the machine (use, maintenance, spare parts) always-state model number, manufacturing Year and Order. This date can be found on the parts identification label.

Manufacturer:

Condux International, Inc.

145 Kingswood Drive

Mankato, MN 56002-0247

1-507-387-6576

Fax 1-507-387-1442

E-mail: cndxinfo@condux.com

	<p>If you have questions on:</p> <p>SAFETY - OPERATIONS - APPLICATIONS</p> <p>CALL 1-800-533-2077</p>
---	--

Table of Contents

1	General Information	4	9	Troubleshooting Guide	21
2	Technical Specifications	6	10	Appendices	27
	A. Operational Conditions	6		A. Engine	27
	B. Hydraulic Oil	6		B. Hydraulic Oil Filters	27
	C. Calibration	6		C. Suggested Lubricants	28
3	Safety Information	7		D. Maintenance Points	29
	A. Safety Devices	7		E. Trlr, APS-75 08771000-01	30
	B. Emergency Stop Device	7		F. Trlr, APS-75 08771000-02	31
	C. Periodic Operations	7		G. Trlr, APS-75 08771000-03	32
	D. Cautions & Warnings	7		H. Trlr, APS-75 08771000-05	33
	E. Pulling Rope Failure	7		I. Trlr, APS-75 08771000-06	34
	F. Rotating Component Pinch-Point Hazards	8		J. Fairlea	35
	G. Crushing Injury when Loading or Unloading Rope or Conductor Reels	8		K. Arm, Complete-ASSY	36
	H. Electrostatic Discharges	8		L. Arm, Boom Pivot Extensn	37
	I. Inhalation Engine Exhausting Gas	8		M. Cap, Anti Slosh Hyd Filler	38
4	Transporting	9		N. Panel, Control-Assem-APS75	39
	A. Machine Lifting	9		O. Fairlead, Capstan Mount APS-75	40
	B. Packing for Shipment	9		P. Fairlead, Midway Guide APS-75	41
	C. Unpacking	9			
	D. Towing	9	11	Notes Page	42
5	Versatile Control Panel	10	12	Warranty Information	43
	A. Engine Speed Throttle	10			
	B. Fuse	10			
	C. Master Switch	10			
	D. Engine Module	10			
	E. Electronic Controls & Display	11			
	F. Filter Lights	11			
	G. Emergency Stop Buttons	11			
	H. Mobile Joystick Module	11			
	I. Alarm Light	11			
	J. Takeup Reel Pressure Relief Valve	11			
6	Advanced Electronic Control	12			
	A. Main Screen	12			
	B. Setup	12			
	C. Reset Length	13			
	D. Tension Limit	13			
	E. Record Pull Data	14			
	F. Export Data	14			
7	Operating Procedures	15			
	A. Positioning the Trailer & Lower Boom	15			
	B. Stabilize Trailer	15			
	C. Start Puller	16			
	D. Payout Winch Line	16			
	E. Prepare for Pullback	17			
	F. Pullback	17			
	G. Shut down	17			
8	Maintenance	18			
	A. General Procedures	18			
	B. Fluid Levels	18			
	C. Suggested Lubricants	18			
	D. Hydraulic Circuit Maintenance	18			
	E. Reduction Unit and Reel Winder Negative Brake Maintenance	19			
	F. Oil Maintenance	19			
	G. Greasing	19			
	H. Electronics Note	20			
	I. Summary Table for Ordinary Maintenance	20			
	J. Extended Storage	20			

General Information

1.

PRODUCT DESCRIPTION

The APS75 pulling trailer provides up to 7,500 lbs of pulling force, and a max speed of 170 ft/min. It comes equipped with an Electronic Control system which monitors system pressures, engine data, pull distance and pull force. Tension Limit control, Pull Data Recording, and HP limiting, which controls pull speed to eliminate engine stall, are also standard. The APS75 Pulling Trailer includes an engine noise reduction kit and 2600 feet of 3/8" anti-twist rope. Anti-twist rope offers high flexibility, complete stability to rotation and increased efficiency during pulling operation.

An optional hydraulic arm control allows effortless positioning of the extension arm. Up, Down, Right, and Left can all be controlled from the operator station. Condux International manufactures a complete line of cable installation tools and equipment.

SAFETY INFORMATION

- Only trained and qualified operators should use this machine.
- Qualified operators are those persons who have received training from the machine owner's company or, alternatively, from the manufacturer.
- This machine must be used only for the work it was designed for.
- This machine should not be used with unauthorized personnel on the work site.
- For any questions regarding operation, function, maintenance, etc., contact the After-sales Service of the manufacturer.

OPERATOR INFORMATION

- Operators must be aware of all local, state and federal safety regulations governing the use of this equipment.
- Operators must wear suitable clothing to reduce the possibility of entanglement in the machine's moving parts. They should avoid the wearing of chains, and other jewelry for the same reason.
- Operators must use personal protective gear (i.e. gloves, boots, helmet, etc.).
- Operators must carefully follow hazard related instructions contained in this instruction manual or indicated on the machine.
- This machine's work area should be free as possible of oil or other liquid spills as well as materials or equipment that may be considered as an obstacle to proper operation.
- The operator must absolutely avoid the direct inhalation of the system's engine exhaust gas.

GENERAL MAINTENANCE INFORMATION

- It is absolutely forbidden to carry out any maintenance, or adjust any settings on this machine while pulling (except for those indicated in this manual).
- Before carrying out any maintenance, stop the engine (except for those instances indicated otherwise in this manual) and wait till the system components subject to heating have cooled sufficiently
- All the maintenance performed on this machine must be carried out on a level surface and while the system is not under load.
- Authorized and trained personnel must perform all of the maintenance, both scheduled maintenance and repair. Authorized and trained personnel are those persons who have received training on the maintenance of this equipment from the machine owner's company or, as alternative, from the manufacturer.
- Maintenance personnel must wear suitable clothes to reduce the possibility of entanglement in the machine's moving parts. They should avoid the wearing of chains, and other jewelry for the same reason.
- Operators must use personal protective gear (i.e. gloves, boots, helmet, etc.).

- All maintenance operations, both scheduled and repair, must be carried out per the instructions included in this manual or following technical instructions provided by the manufacturer. Failure to follow these instructions relieves the manufacturer from any responsibility and voids their warranty.

MACHINE USAGE

The machine must not be used:

- For lifting persons and/or goods
- In a location where the machine cannot be positioned and anchored in a proper way
- In areas with brush or other materials that can be easily set on fire
- In closed/unventilated sites or those poorly ventilated (tunnel or similar)
- At sites where fuels or explosives are present
- For structure demolition
- For the pulling of elastic elements
- With ropes or joints having a bigger diameter than that specified in this manual
- With over-ridden or broken safety system devices
- For handling trucks or other movable equipment

RESPONSIBILITY

Use of the machine in situations different from those indicated in paragraph 2.3 (Typology and using field), or those not described in this manual, is to be considered extremely dangerous and/or forbidden.

Persons not using recommended restraints cause a situation of improper use, and relieve the manufacturer from any responsibility for accidents, injuries to persons or damage to property. The manufacturer's warranty is also voided.

Similarly, the manufacturer's responsibility ends when the following situations occur:

- Tampering and/or modifying of the system without the manufacturer's written acceptance (in this case the operator becomes the manufacturer assuming all obligations and responsibilities, both civil and penal).
- The use of non-original spare parts.
- Poor maintenance.
- Use with disconnected or over-ridden safety devices.
- For the connection to machine and/or plans not produced and not directly authorized by the manufacturer in a written acceptance.

OPERATORS MANUAL

- Information contained in this manual applies to all the operators charged with the use and/or the maintenance of the machine.
- This instruction manual is not a training manual.
- Before using the machine the job site supervisor and the operators must read this instruction manual.
- The supervisor is obliged to inform all operators about the instructions contained in this manual.
- All operators user must carefully follow the instructions contained in this manual.
- Before using the machine the operator must know the locations and the functions of all the controls.
- The job site supervisor must verify that the instructions contained in this manual are applied.
- This instruction manual must be kept with the machine, for the entire life of the machine, so it is available to all potential users and operators.
- The instruction manual must be kept in a sheltered and dry place.

Technical Specifications

2

The Condux APS75 Hydraulic Underground Pulling Trailer provides up to 7500 lbs of continuous pulling force. Designed for installing underground cable, the APS75 is completely self-contained and transports easily from jobsite to jobsite. Industry leading features like a standard Electronic Control System, a mobile joystick, and anti-twist rope make the APS75 the most advanced puller in the market today.

GENERAL SPECIFICATIONS PULLER	
MAX LINE PULL, POUNDS	7500
MAX PULLING SPEED, FEET PER MINUTE	170
BULL WHEEL DIA., INCHES	9
MAX ROPE DIA., INCHES	3/8
FEET OF ROPE	2600
ENGINE TYPE	DIESEL
HORSEPOWER	49 T4F
ELECTRICAL SYSTEM	12 Volt

A. OPERATIONAL CONDITIONS

Temperature: from -10°C to +40°C, 15-105° F
 Relevant moisture: from 30% to 90% ± 5%.
 Weather conditions: any (in line with working conditions).
 Natural and/or artificial lighting of the working site.

B. HYDRAULIC OIL

When using the machine always keep in mind operating conditions and their effect on the possibility of your exceeding the following temperature limits for the system's hydraulic oil.



0°F -18°C	20°F -7°C	40°F 4°C	60°F 16°C	75°F 24°C	85°F 30°C	95°F 35°C	110°F 43°C
←		ISO VG 22 →					
	←		ISO VG 32 →				
		←		ISO VG 46 →			

For additional information concerning the hydraulic oil, see chapter "Maintenance" and the attached comparative table of the oils used on the machine.

C. CALIBRATION

This unit uses Hydraulic Working Pressure to calculate pulling tension. As a result, the tension readings must be set under dynamic loading. The unit should not require regular calibration, although Condux can review and reset the load curve at their factory.

Safety Information

3.

A. SAFETY DEVICES

Machine has been equipped with the following safety devices:

- A load-limiting device that automatically disables the pump once the max. pre-set load value has been exceeded
- Where possible, guards and covers are provided to protect personnel from moving parts

!DANGER: it is absolutely forbidden to use this machine with protective guards removed or with damaged or disconnected safety devices.



B. EMERGENCY STOP DEVICE

Two emergency stop buttons are provided - One on the main control panel and one on the mobile joystick (Figure 1) Pushing it immediately shut off the puller.



Figure 1. Emergency Stop Buttons

!CAUTION: The emergency stop WILL shut down the engine. Do not attempt to use the emergency stop to shut down the system.



C. PERIODIC OPERATIONS

Proper functioning of safety systems should be verified daily.

!CAUTION: Any customer alterations to the provided safety devices relieves the manufacturer of any responsibility for any resulting damage of property or injury to personnel.



D. CAUTIONS & WARNINGS

When operating this machine, users must be aware of other risks associated with the work for which the machine is intended.

E. PULLING ROPE FAILURE

Pulling rope failure will cause uncontrolled movement of the entire machine. This movement, as well as the danger presented by the recoil of the pulling rope and/or conductor, can cause serious injury or death.

To reduce operator exposure to these dangers operators must:

- Regularly check the rope and replace it as soon as defects or signs of wear are detected

- Assume only the recommended operation locations indicated in this manual (Figure 2)



!WARNING: Rope failure can cause serious injury or death if safety precautions are not followed.

F. ROTATING COMPONENT PINCH-POINT HAZARDS

Due to the nature of the work being performed and important system functionality, it is not possible to fully guard all rotating components.

To minimize risks operators must:

- Avoid any contact with the machine's rotating components
- Follow the anchoring instructions described in this manual
- Follow all recommendations in this manual regarding the use of personal safety equipment

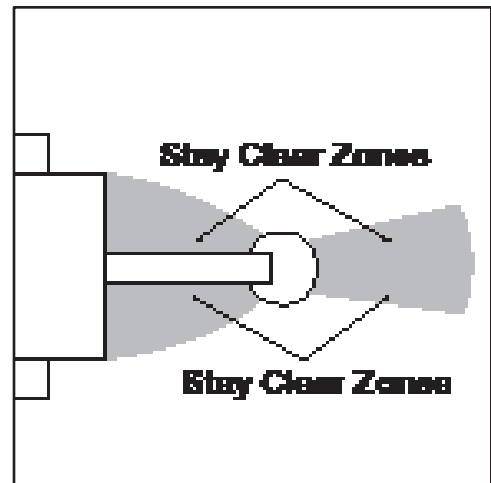

Figure 2. Recommended Operating Locations



!DANGER: Do not operate machine when individuals are near exposed rotating components. Serious injury may occur.

G. CRUSHING INJURY WHEN LOADING OR UNLOADING ROPE OR CONDUCTOR REELS

Operators must know the proper methods for executing these tasks and should be trained to do them properly.

H. ELECTROSTATIC DISCHARGES

To reduce the risk presented by static electric charge build up in the ropes and conductors during pulling operations, the machine must be properly grounded.

To minimize these risks operators must:

- Be trained in, and apply, the proper methods used to ground the machine during before using the machine.

I. INHALATION ENGINE EXHAUSTING GAS

To minimize these risks operators must:

- Assume the proper operating position during operation and use appropriate safety equipment as needed

Transporting

A. MACHINE LIFTING

For machine lifting use only devices (overhead traveling cranes, lift trucks, ropes, cables, hooks, etc.) with a capacity equal to the weight to be lifted.

Personnel should not be on the machine when it is lifted.

!DANGER: Failure to follow the recommendations in this section may create a dangerous situation and/or damage to the machine. The manufacturer's warranty may also become void as a result.



B. PACKAGING FOR SHIPMENT

Transport by land by truck

Certain surfaces may be protected by cardboard and/or plywood and/or polyethylene film.

To prevent movement, use nailed wheel chocks. Attach the machine to the floor of a truck box or trailer using chains and hooks at the attachment points provided.

C. UNPACKING

When receiving the machine verify the condition of the package; immediately notify the transportation company and the manufacturer (use photos whenever possible) of any damage that may have occurred during shipment.

Verify that the supplied product matches that which was ordered; immediately advise the manufacturer if there is a discrepancy.

Use caution when unpacking to avoid damaging the product.

!CAUTION: Disposal of all packaging materials must be in accordance with local regulations.



D. TOWING

This machine is designed for towing at highway speeds. No personnel may ride on the machine at any time while towing the machine at ANY speed.

Versatile Control Panel

5

The Electronic Control and Monitoring system is an integral part of the APS75 Underground Pulling Trailer. In addition to monitoring pulling tensions, pull distance, hydraulic pressures, and fuel levels, it also allows the operator to record pull data and set tension limits.

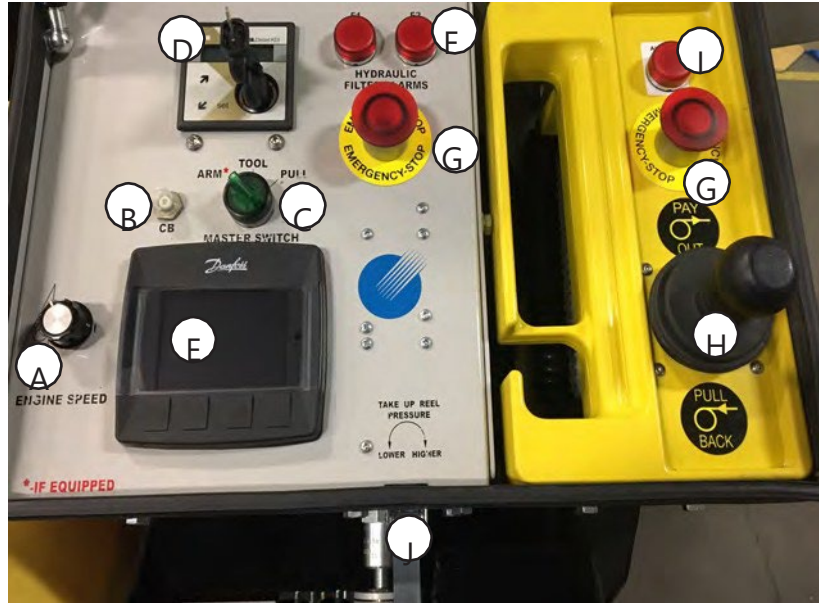

A. ENGINE SPEED THROTTLE.

Rotary throttle for accurate even increase in throttle speed.

B. FUSE

15A fuse to protect control panel electronics

C. MASTER SWITCH

A three position switch - From left:

1. ARM* - This position can only be used with the optional hydraulic arm control. see section 7.A on page 15 for detailed instructions on using this feature
2. TOOL - Engages 2000 psi, 7gpm tool circuit.
3. PULL - Switch will light when in this position. The machine will ONLY pull cable when the Master Switch is in this position.

D. ENGINE MODULE

Engine module includes ignition key and engine indicator lights:

	Engine Protection - On while engine is running properly
	Fuel Indicator- NOT USED
	Oil Pressure - Turns on when oil pressure is low
	Battery Recharge - Turns on in case of battery recharge failure
	Coolant Over Temp - Turns on when coolant temp is above safe level
	Red Light - Not Defined for this system
	Red Light - Not Defined for this system
	Glow Plug Indicator - Remains on while glowplugs are heating

	Air Filter Indicator - Turn on in case of air filter obstruction
--	--

E. ELECTRONIC CONTROLS AND DISPLAY

See Section 6 for detailed instructions and information

F. FILTER LIGHTS

Filter lights, F1 and F2 indicate that a hydraulic filter needs to be replaced. Replacement filters and maintenance instructions can be found in Section 12.A of this manual.

G. EMERGENCY STOP BUTTONS

Emergency stop buttons are located on the main panel and on the mobile joystick. Pressing the E-Stop button will shut down the hydraulic circuit but will NOT shut off the engine. Twist and pull to reset.

H. MOBILE JOYSTICK MODULE

Joystick module can be docked in the control panel, or can be taken out and carried up to 15 feet from the puller if desired. The joystick module is connected to the Control Panel by a coiled cable.

I. ALARM LIGHT

The alarm light, located on the mobile joystick, lets an operator who is using the joystick away from the machine know that an Emergency Stop button has been pressed or that the Tension Limit has been exceeded.

J. TAKEUP REEL PRESSURE RELIEF VALVE

Pressure Relief Valve controls tension on the Take-Up Reel. Pressure is displayed on the Electronic Control Screen, Shown in section 6.

Advanced Electronic Control

6.

The Electronic Control and Monitoring system is an integral part of the APS75 Underground Pulling Trailer. In addition to monitoring pulling tensions, pull distance, hydraulic pressures, and fuel levels, it also allows the operator to record pull data and set tension limits.

A. MAIN SCREEN

The Main Screen displays everything the operator needs to see during the course of a pull (Figure 2).

- Pull Tension
- Distance Counter
- Recording Status
- Sample Rate
- Soft Buttons

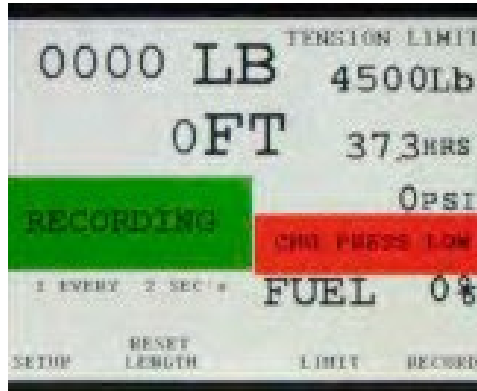

- Tension Limit and status
- Engine Hours
- TakeUp Reel Pressure
- Fuel Level
- Soft Buttons

Figure 2. Main Screen

The four buttons are defined at the bottom of the screen. (See "Soft Buttons" in Figure 2) To access any of these menus from the main screen, press and hold the button for 1-2 seconds.

To navigate through Setup, Limit, and Record screens, use the **56** buttons to scroll through lists, and the **4** button or Select button to select or enter options. Pressing the Return button will move back one screen.

B. SETUP (Figure 3)

1. FILE TRANSFER - Currently displays a msg that this option will be available in the future (via a downloadable firmware upgrade). This feature will allow the user to transfer pull data to a USB flash drive.
2. SAMPLE RATE - Sample Rate is how often the recorder will store data from a pull. Use the **56** arrows to select 1 sample / 1 second, 2 sec, 5 sec, or 10 sec. This rate will be displayed on the main screen when Recording is turned ON. (Figure 4)

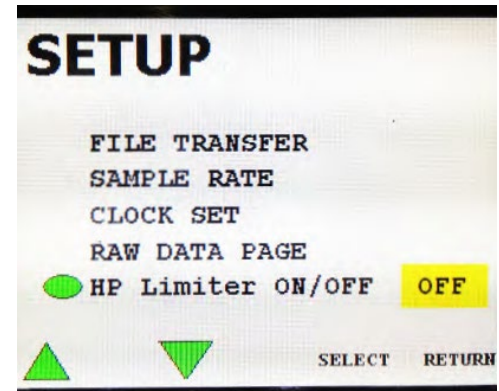

Figure 3. Setup Screen

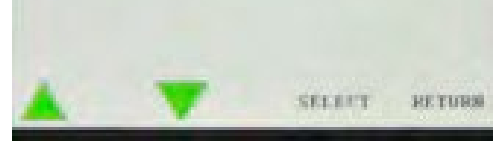

Figure 4. Sample Rate Screen

3. **CLOCK SET** - This screen displays Date and Time. Press and hold 56 together to enter EDIT mode. Use the 4 button to move between units. Use the 56 to change the value of each unit. **NOTE: Recorded data is time stamped, so it is important to have the clock set in order to be able to match data to a specific pull (Figure 5).**



Figure 5. Clock Set Screen

4. **RAW DATA** - Displays raw data for trouble shooting purposes. The data shown is Work Pressure, Charge Pressure, Reel Pressure, Engine RPM, and Joystick Actuation.

5. **HP LIMITING ON/OFF** - Turns HP Limiting feature on or off. HP Limiting controls pump stroke when running at high speed to eliminate engine stall due to overloading. When running in the mid throttle range, it may be preferable to have this feature turned off to avoid having the controller attempt to reduce pump stroke.

C. RESET LENGTH (Figure 6)

The Distance Counter on the APS75 Electronic Control maintains length data, even after machine shut down. To reset the counter to 0 at any time, press and hold the RESET LENGTH button until the footage returns to 0.

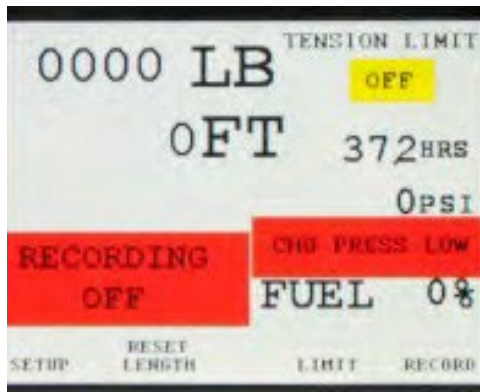

Figure 6. Reset Length

D. TENSION LIMIT (Figure 7)

The APS75 Electronic Controls allow the user to limit the pulling tension applied to the cable.

- Press and hold LIMIT button until Limit screen is displayed.
- Limit status is displayed at the top of the screen as LIMIT OFF or LIMIT ON.
- Scroll to LIMIT, and press 4. Use the 56 arrows to change the Tension Limit value, and the 4 button to switch between 100's and 1000's digits.
- Press RETURN to return to the main LIMIT screen.
- Scroll to LIMIT ON/OFF and press 4 to turn Limit feature on or off. - Status displayed at the top of the screen will change.
- Press RETURN to return to the Main screen.



Figure 7. Tension Limit



Figure 8. Emergency Stop Screen

- Tension Limiting status is displayed in the upper right hand corner of the Main Screen (Figure 2)
- If Tension Limiting is turned ON, and the set tension limit is exceeded during a pull, the controller will disable the pump by forcing it to neutral. The Screen will display a red message instructing the user to return the joystick to Neutral. Press the button labeled RESET to return to the main screen. (Figure 8) **NOTE: The system will not reset unless the joystick is in the Neutral position.**

E. RECORDING PULL DATA

The APS75 Electronic Controls allow the user to record pull data, including time of pull, pull distance, and pulling tensions. Data can be downloaded to a computer or exported via a USB flash drive. The Electronic Display holds 16MB of onboard flash memory, which is space for over 100 hours of pull data. Once full, the Recorder will overwrite the oldest data in its memory. (Figure 9)

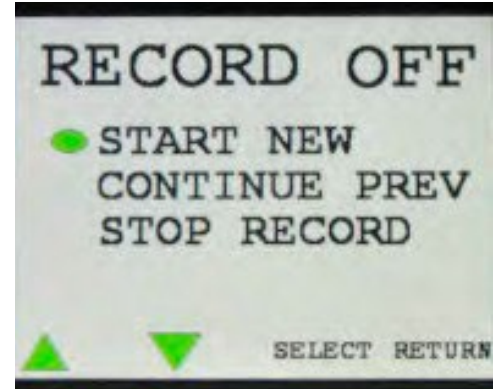

Figure 9. Record Screen

- Press and hold RECORD button until Record screen is displayed.
- Record status is displayed at the top of the RECORD screen as "RECORD OFF" or "RECORD ON".
- To begin recording a new pull, scroll to START NEW and press SELECT.
- To continue recording a pull that has been interrupted, select CONTINUE PREV.
- Press RETURN to return to the Main screen.
- If the Record function is turned OFF, RECORDING OFF will be displayed in a red block on the Main screen. If the Recording function is turned ON, RECORDING will be displayed on the Main screen, along with the sample rate at which points are being recorded (Figure 2)
- At the end of a pull, select STOP RECORDING to close the file.

F. EXPORTING DATA

Pull Data can be exported from the APS75 Control Panel through a USB port located in the Mobile Joystick docking station. (Figure 10) Please see the included addendum for additional details for exporting and viewing data.



Figure 10. USB Port

Operating Procedures

It is essential that the APS75 Underground Pulling Trailer be properly set up before operation. Using the following procedure will allow the unit to be set up in a short period of time and yield optimum performance.

7.

A. POSITIONING THE TRAILER & LOWER BOOM

Position the APS75 Puller within an approximate boom arm reach of the manhole or duct bank. After trailer is positioned, lower boom arm.

NOTE: It may be necessary to payout a small amount of winch line (releasing it from the boom) first to allow the boom to be lowered. If so please refer to Steps C and D before proceeding.

NOTE: When operating the APS75 on a new build site or on soft ground you will need to block the front jacks to prevent them from sinking. Pulling the arm down until the lift cylinders cross the arm's pivot point could result in damage to the puller during the pulling operation or when lifting the arm for transport. An optional a-frame or manhole adapter can reduce or eliminate these concerns.



Figure 1. Remove Traveling Pin

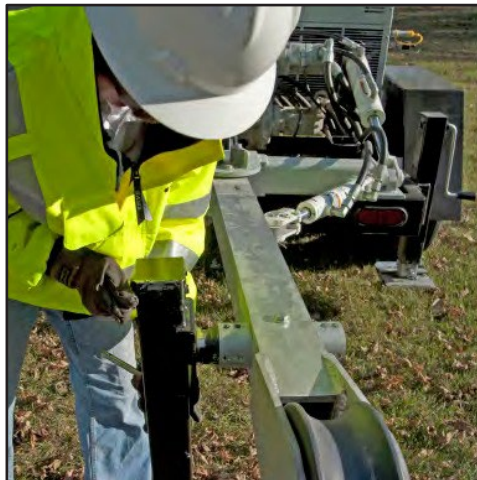

Figure 2. Lower Arm and Install Jacks

Remove the traveling pin and carefully lower the boom. (Figure 1). Install jacks, and use jacks to raise arm into desired position. (Figure 2). Now that the boom is in place, minor adjustments in the puller's position can be made if necessary for optimum working alignment. If using the Hydraulic Arm Control option, turn Master Switch to *ARM position. The control valve is mounted below the Control Panel. The left lever controls right/left position. The right lever controls up/down position.

B. STABILIZE TRAILER

After the APS75 is properly positioned, place wheel chocks to prevent trailer movement.

NOTE: The trailer may be disconnected from the tow vehicle or left connected depending on specific site conditions.

After placing wheel chocks, stabilize the trailer using the five supplied adjustable leveling jacks - two on boom arm, two at rear of trailer, and one on trailer tongue. Raise and lower jacks by rotating crank handle (Figure 3A). Adjust the two jacks on the boom arm until the arm is level to the ground.

NOTE: If using the APS75 with hydraulic Jacks to stabilize the APS75 use hydraulic control panel (Figure 3B) located below the control box to raise and lower hydraulic cylinders.



Figure 3A. Lower Crank Jacks

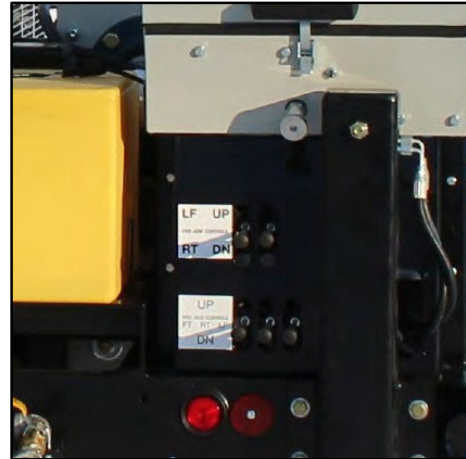

Figure 3B. Lower Hydraulic Jacks

C. EXTENDING THE BOOM ARM (for APS75 units with extendable arm) After stabilizing the APS75 you can then extend the boom by removing the locking pin and manually extending the arm to desired position.

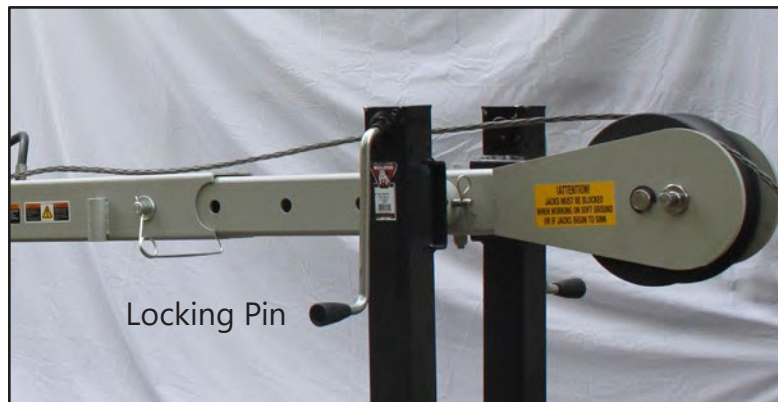

Figure 4A. Remove locking pin to extend arm

C. START PULLER

Open the Control Panel lid on the side of the APS-75. Ensure that the Joystick is in the mid or neutral position, and turn the Take-up Reel Pressure Control Valve counter-clockwise for minimum pressure. Move the engine speed throttle lever to minimum speed (Full Up Position).

Turn the key to "Run" (vertical) position. The Glow Plug Indicator will light. Hold until Glow Plug Indicator light goes out (Figure 4B).

Turn the ignition key clock-wise to engage Starter (Figure 4B). When the engine starts, release key back to the Run (vertical) position.

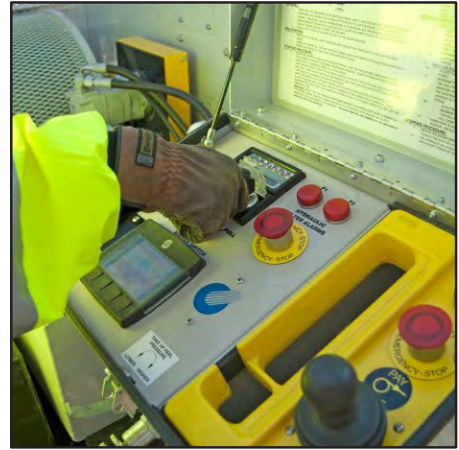

Figure 4B. Turn Key to "Run" Position

Allow the engine and hydraulic system to warm up at idle speed for 5-10 minutes. Filter alarms may light when the system is cold. If these lights are lit during operation, replace the indicated filter.

IMPORTANT: After starting the engine, verify that the hydraulic pressure warning is not flashing on the display screen at engine idle speed. If this warning appears during operation, STOP IMMEDIATELY TO FIX THE PROBLEM. Please refer to the troubleshooting guide at the end of this manual.

D. PAYOUT WINCH LINE

Turn the Take-Up Reel Pressure Control Valve full counter clock wise. During payout, this pressure should be between 500-800 psi. Increase engine speed by moving the throttle lever to the middle or bottom detent. Payout winchline by pushing the joystick up towards the "payout" label. Increase Take-Up Reel pressure as needed to ensure constant tension on the winchline. The joystick is infinitely variable so payout speed can be varied by the degree to which the joystick is moved.

IMPORTANT: Always keep tension on the winch line when paying it out to prevent slack from developing in bull wheel.

In typical applications, the winch line will need to be paid out to reach the work area first, i.e. manhole, duct bank, etc. The winch line can then either be pulled through duct bank with a pulling rope or tape, or installed with a Condux Winch Line Blower.

E. PREPARE FOR PULLBACK

Adjust the Maximum Tension Limit (if desired) to the desired maximum pulling tension value (measure in lbs). See detailed instructions on page 13.

Turn on RECORD function (if desired) to record pull data. See detailed instructions on page 14. Select from the following three options:

1. Record New - used when starting a new pull
2. Continue Prev. - used when a pull has been interrupted and it is necessary to restart the Record function
3. Stop Record - used at the end of a pull to shut off record function

G. PULLBACK

Increase engine speed to maximum - full down in the last detent. To start pullback, pull the joystick down slowly towards the "pullback" label. The speed of the pullback can be increased by increasing the pull on the joystick. During pullback make sure to monitor pull force and distance. (Figures 6 & 7)

NOTE: An automatic system will optimize the horsepower required by the hydraulic system for maximum pull speed and force. This is done to prevent the engine from being overloaded or stalling. This will be noticeable when the engine speed drops below 3300 rpm and the joystick is in the full down position.

H. SHUT DOWN

At the end of the pull, relieve pulling rope tension using the joystick. Allow the machine to cool down for five minutes before turning off the ignition key. The hydraulic oil cooler is automatic, and will start and stop as required. It is normal for it to run for a short period of time after the engine is turned off.



Figure 6. Monitor Pulling Tension and Distance



Figure 7. Use Joystick to Increase the Pullback Speed

Maintenance

8.

A. GENERAL PROCEDURES

!CAUTION: Any customer repairs not authorized by the manufacturer relieves the manufacturer of any responsibility for any resulting damage of property or injury to personnel.



B. FLUID LEVELS

Due to safety and/or regulatory reasons, this machine may arrive without hydraulic oil and fuel.

Fill the levels as per the following table:

Fluids	Quantity
Hydraulic oil level (Maintenance drawing, item 3)	79.5 l – 21.0 gal
Engine oil level (see enclosed engine booklet)	3.2 l - 3.3 qt
Fuel level (Maintenance drawing, item 6)	68 l –18 gal
Gearbox cases	1 l - 1 qt



!CAUTION: Not filling fluids to those levels specified above will cause serious damage to system components and voids all product warranties.



!DANGER: Purposely ingesting hydraulic liquids, fuels and cooling liquids is potentially lethal.

C. SUGGESTED LUBRICANTS

The manufacturer tests the machine with the following oils and lubricants: hydraulic circuit: INDOL HYDRAULIC OIL 32 (ISO VG 32).

Alternates must be chosen from the enclosed table “SUGGESTED LUBRICANTS”. It is possible to use different products, but they must have the same characteristics and ISO specifications.



!CAUTION: The use of lubricants not in conformity with the technical specifications indicated in the referenced table can seriously damage the machine, its components and voids all product warranties.



!DANGER: Let the engine cool prior to performing any maintenance, or before refueling.

D. HYDRAULIC CIRCUIT MAINTENANCE

Change the hydraulic oil after 500 working hours, then every 1500 hours (or at least annually).

To drain the hydraulic oil remove the hydraulic tank’s drain plug (Maintenance drawing, item 2).



!DANGER: Allow the hydraulic oil to completely cool before removing it. Always use suitable safety gear (gloves, etc.).

!CAUTION: Disposal of all drained system oils and fluids must be in accordance with local regulations.



Fill the hydraulic oil using the filler spout designated on (Maintenance drawing, item 1).

!CAUTION: Ensure that no foreign matter enters the system along with the oil; if possible filter the oil with a 10 µm filter.



Replace the filter cartridge after 500 working hours and then, every 1500 hours (or at least annually).

Check that the hydraulic oil filter lamp lights only during start-up. If lit and any other time it indicates that the hydraulic oil filter needs replacing.

For further maintenance instructions on the hydraulic components (pumps and motors) refer to the enclosed documentation.

E. REDUCTION UNIT MAINTENANCE

Change the oil of the bull-wheel reduction unit (Maintenance drawing, item 7) after 100 working hours and, thereafter, every 2500 hours (or at least annually).

To drain the reduction unit use the plugs on the lower part of their housings.

!DANGER: Manufacturer recommends removing gearbox oil when hot. Always use suitable safety gear (gloves, etc.).



!CAUTION: Disposal of all drained system oils and fluids must be in accordance with local regulations.



Fill the oil into the reduction unit using the proper fill spout

!CAUTION: insure that no foreign matter enters the system along with the oil.



For further maintenance instructions on the reduction gear, refer to the enclosed documentation.

F. OIL MAINTENANCE

At least once a year, or as frequently as required, using compressed air, blow all debris from the fins of the oil coolers.

!CAUTION: Personnel cleaning the oil coolers as per above should wear all required personal protective gear, including a respirator.



G. GREASING

Grease all points not automatically lubricated daily, these include: Take-up Reel Bearings, Levelwind Shaft, Pawl, and any other rotating component (Maintenance drawing, items 5 and 8).

Use CASTROL MOLUBALLOY 6040 NLGI 2 (ISO VG 150) grease or equivalent from the enclosed "SUGGESTED LUBRICANTS" table.

H. ELECTRONICS NOTE

When cleaning the machine, avoid direct spraying of water or steam on electronic components or the control panel.

For the other periodic operations refer to the summary table for the ordinary maintenance.

I. SUMMARY TABLE FOR ORDINARY MAINTENANCE

This table lists the recommended service intervals for the systems noted.

Part	Object	Interval				
		Daily	50 h	250 h	500 h	1500 h
Diesel engine	Engine oil	CL		RP		
	Oil filter			RP		
	Cooling liquid	CL				RP
	Air filter			CK		RP
	Fuel	CL				
	Fuel filter				RP	
Hydraulic circuit	Hydraulic oil	CL			RP1	RP(*)
	Filter	CK			RP1	RP(*)
Bull-wheel gear box	Oil	CL	RP1			RP(*)
Reel winder	Gears	GR				
	Chain transmission		GR			
	Level winder screw	GR				
	Pawl	GR	CK			

Legend:

CL Check the level (and possible filling up)

GR Grease

RP Replace

RP1 Replace (only for the first time)

CK Check

(*) Or in any case every year

J. EXTENDED STORAGE

When an extended storage period is anticipated (two months or more) coat external parts with waterproof protectant.

During the storage period, start the machine at least once every two months and let the engine idle for approx. one hour. Do this so that oil enters the hydraulic system and coats all gaskets, O-rings, etc.

The machine should be stored under a roof. Do not tarp the machine as excess moisture may collect under it and cause damage to the system.

If the machine is stored for a year or more, replace the hydraulic circuit's oil and filters prior to startup.

Troubleshooting Guide

9.

PROBLEM:	CAUSE:	SOLUTION:
The diesel engine starter doesn't work.	Burned fuse	Replace
	Run down battery (Light on Kohler Controller)	Recharge or replace
	Disconnected contacts of the ignition system / starter	Reconnect
	Oxidized contacts of the ignition system / starter	Clean or spray with a suitable vaporizer
	Starter out of order	Replace / Technical assistance
Diesel engine doesn't work.	The ignition key not turned to start position	Turn ignition key clockwise to start position and hold until the engine starts
	The glow plug indicator light isn't turned off (On Kohler Controller)	Wait for the glow plug indicator light to turn off before starting
	Fuel problem	Check the fuel level in the tank Check the fuel filter
Diesel engine turns off when releasing the ignition key.	Check of the engine oil pressure	Add engine oil
		Defective sensor—check contacts / replace
		Engine anomaly – technical assistance
	Check of the engine cooling liquid temperature	Add cooling liquid
		Defective sensor—check contacts / replace
		Engine anomaly – technical assistance
The charge pressure is lower than 24 bar – 290psi	Clogged hydraulic oil filter	Replace
	Defective pump	Technical assistance
Diesel engine doesn't increase rpm	Disconnected accelerator cable	Verify and if necessary replace

PROBLEM:	CAUSE:	SOLUTION:
The clogged filter warning light turns on.	Hydraulic oil temperature too low	Allow oil to warm up by running the engine at idle for several minutes.
	The oil is too thick with respect to the environmental conditions	Use oil with lower viscosity as per the indications in the instruction manual
	Clogged hydraulic oil filter	Replace
When starting the control lever, the bull wheels don't work.	E-Stop has been pressed.	Pull up depressed E-Stop Button. Follow instructions on Control Screen to reset the machine
	Tension Limit has been exceeded.	Follow instructions on Control Screen to reset the machine. If Tension Limit continues to be exceeded, increase Limit Value or shut off Limit Control to continue pull.
	The joystick is not sending a signal to the controller.	Verify that the joystick is sending out an appropriate signal by pressing SETUP>RAW DATA and looking at Joystick. Move joystick and verify that the value changes with joystick stroke. - technical assistance.
	Defective pump servo control	Verify the electric voltage – technical assistance
When moving the control lever, the bull-wheels rotate but the rope doesn't move – slips on the bull-wheels.	Reel winder pressure not sufficient	Increase the reel winder pressure
		Replace the adjusting valve for the reel winder pressure
		Reel winder pump problem – technical assistance

PROBLEM:	CAUSE:	SOLUTION:
Diesel engine turns off during operations.	Engine oil pressure too low (Light on Kohler Controller)	Add engine oil
		Defective sensor – check contacts / replace
		Engine anomaly – technical assistance
	Engine cooling liquid temperature is too high (Light on Kohler Controller)	Add cooling liquid
		Defective sensor – check contacts / replace
	Engine overheating – technical assistance	
Engine has been overloaded and stalled	When engine starts to slow, reduce joystick stroke.	
Excessive hydraulic oil temperature.	The fan of the hydraulic oil doesn't work	Verify the electric contact of the temperature bulb on the radiator
		Verify the electric contact of the ventilator ignition selector on the control panel
	Overused machine	Wait for oil to cool. Hydraulic oil cooler should run automatically when oil temperature exceeds temp limit.
A unexpected stop happens when returning to center position with the control lever	Hydraulic pump with defective zero setting	Carry out the hydraulic and mechanic zero setting – technical assistance

PROBLEM:	CAUSE:	SOLUTION:
The machine doesn't reach the max. pull performances.	Diesel engine rpm not sufficient	Speed up the engine
	Diesel engine decreases rpm and turns off	Decrease pull on the joystick
	Excessive hydraulic oil temperature	Wait for oil to cool. Hydraulic oil cooler should run automatically when oil temperature exceeds temp limit.
	Insufficient fuel feeding at diesel engine	Check the fuel filter
Fuel feeding system to be adjusted – Technical service		
The machine doesn't increase speed.	Diesel engine rpm not sufficient	Speed up the engine
	Diesel engine decreases rpm and turns off	Decrease pull on joystick – the applied pull doesn't allow to reach higher speed
	Excessive hydraulic oil temperature	Wait for oil to cool. Hydraulic oil cooler should run automatically when oil temperature exceeds temp limit.
	Insufficient fuel feeding at diesel engine	Check the fuel filter
Fuel feeding system to be adjusted – Technical service		

Appendices

10

QUICK REF. SERVICE & PARTS LIST

A. ENGINE

Condux Part #	Manufacturer	Engine Model
P.N.	Kohler	KDI 1903TCR
Engine Service Part		Part Number
02291828	Oil filter	ED0021750010S
02291825	Fuel Filter	ED0021753180S
02291827	Pre-Air Filter	ED0021751750S
02291826	Air Filter	ED0021751260S
N/A	Fan Belt	ED0024403380S

B. HYDRAULIC OIL FILTERS

Item No.	Service Part	MFG	MFG Item No.	Notes
02291378	Hydraulic Oil Filter Pressure	ZINGA	ZME16L/ZME16LP	
		Donaldson	P164378	
		WIX	51494	
		Fleetguard	HF6553	
02292757	Hydraulic Oil Filter Return (Element)	MP Filtration	MF1801A06HBEP01	2019/earlier DFP Unit (Rough Surface Tank)
		WIX	R20C125TB	
		Donaldson	P171536	
02292647	Hydraulic Oil Filter Return (Element)	ZINGA	ZSRE40910	2020/later Force America Unit (Smooth Surface Tank)
		Donaldson	P163910	
		WIX	57841	
		Fleetguard	HF6110/HF6111	
		MP Filtration	MP8302	

* See Engine Manual or Recommended Lubricants chart for temperature variances.

Ø All filters, parts, and service for the engine can be found through your local Kohler distributor. Your local distributor can be found at:

Kohler Engines www.kohlerengines.com 1-800-544-2444
USA & Canada only

B. SUGGESTED LUBRICANTS

SUGGESTED LUBRICANTS											
TYPE	HYDRAULIC CIRCUIT AND STATIONARY BRAKE					GEAR BOX				GREASE	ENGINE OIL
	UNIVERSAL OIL ATF	ARCTIC -30°C	COLD -10°C	TEMPERATE 30°C	TROPICAL 40°C+	ARCTIC -30°C	COLD -10°C	TEMPERATE 30°C	TROPICAL 40°C+	NLGI TYPE	
VISCOSITY (ISO 3448)	VG 33-VG 39	VG22	VG32	VG46	VG68	VG100	VG150	VG220	VG320	NLGI 2	SAE 10w-40
SUGGESTED GENERAL MANUFACTURERS											
CASTROL	DEXRON II	HYPIN AWS22	HYPIN AWS 32	HYPIN AWS 46	HYPIN AWS 68	ALPHA SP 100	ALPHA SP 150	ALPHA SP 220	ALPHA SP 320	SUPERGREASE 2	
MOBIL	ATF 200	DTE 22	DTE 24	DTE 25	DTE 26	MOBILGEAR 627	MOBILGEAR 629	MOBILGEAR 630	MOBILGEAR 632	MOBILUX EP 2	
SHELL	DONAX TM	TELLUS 22	TELLUS 32	TELLUS 46	TELLUS 68	OMALA 100	OMALA 150	OMALA 220	OMALA 320	SUPERGREASE EP 2	

C. MAINTENANCE POINTS

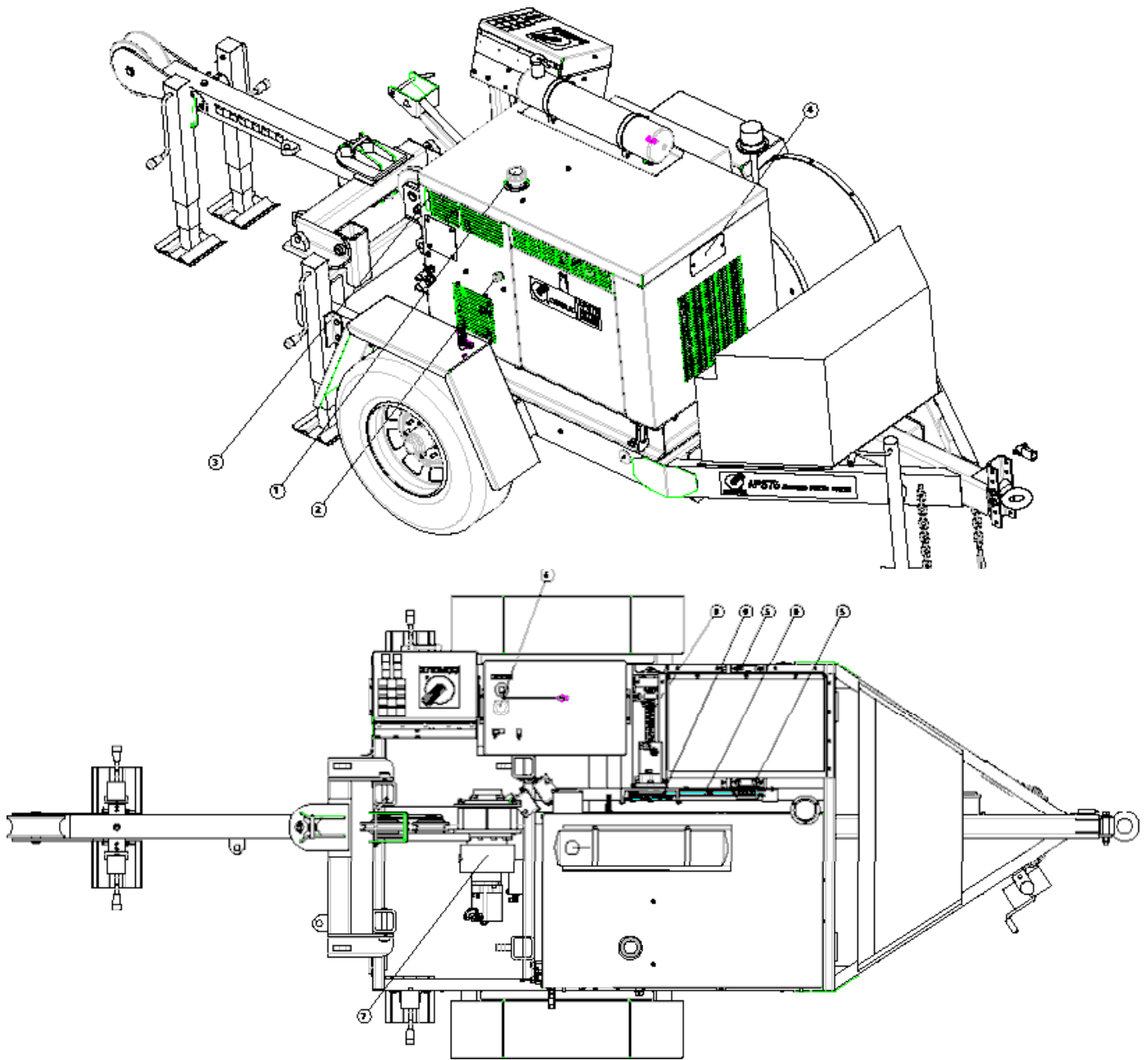

MAINTENANCE POINTS
08771000---3---4

ITEM	DESCRIPTION
1	HYDRAULIC OIL FILL
2	HYDRAULIC OIL DRAIN
3	HYDRAULIC OIL LEVEL GAUGE
4	ENGINE COOLANT FILL
5	GREASE POINT --- REEL BEARINGS
6	FUEL FILL (DIESEL ONLY)
7	GEARBOX OIL FILL
8	GREASE POINT --- LEVELWIND SHAFT
9	GREASE POINT --- CHAINS

D. TRLR, APS-75 7500LB CABLE TRLR

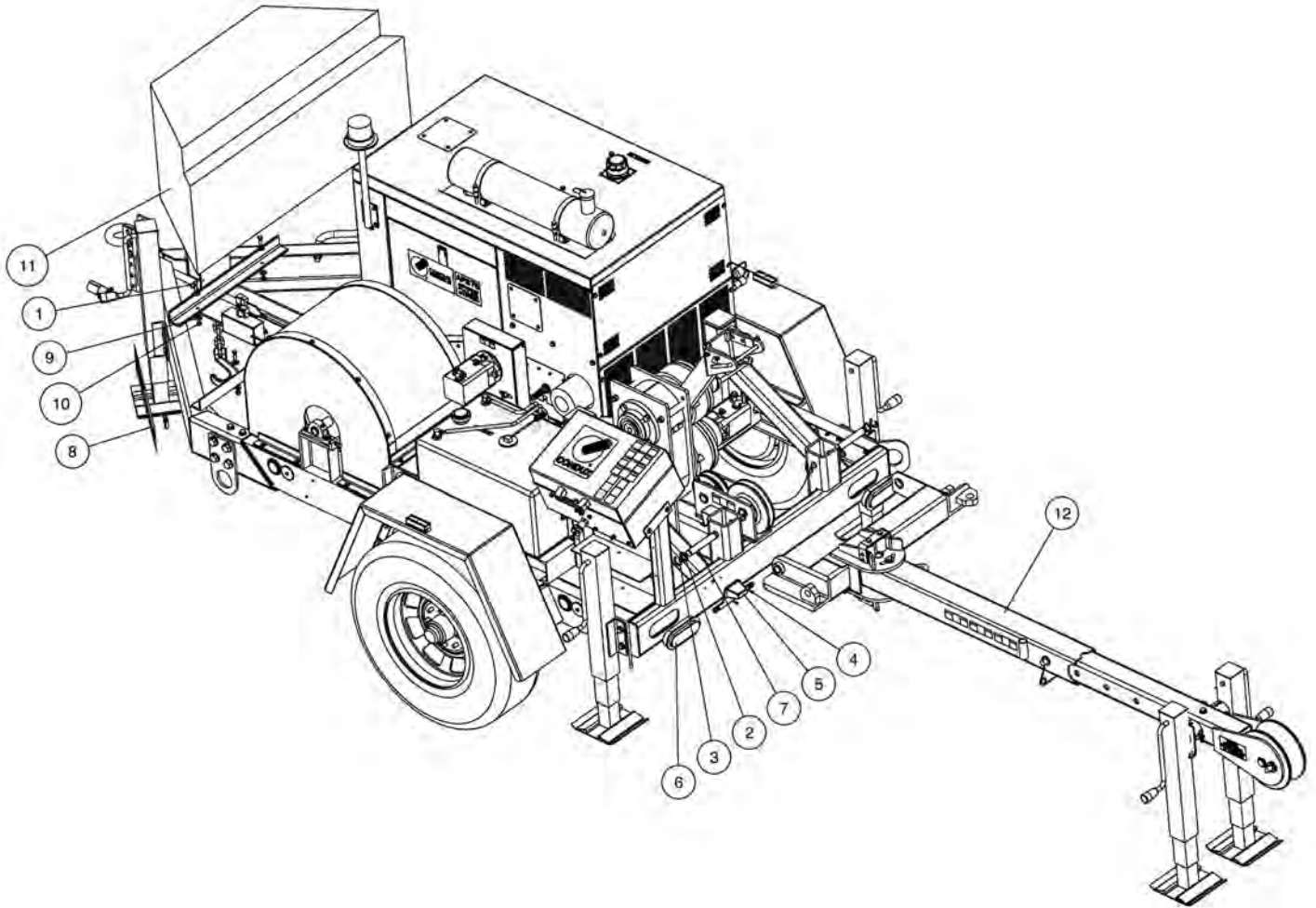

**TRAILER PULLER APS-75 ASSY
08771000-01**

ITEM	PART NO	DESCRIPTION	QTY
1	02032000	CAPSCREW,0.37-16X1.25 HHSTGR8 YZ	4
2	02204800	BEARING,THR 1.003-1.504-0.120	2
3	02222900	RING,RETAINING 1.000 EXT	4
4	02230401	SCREW,TAP .190-24X0.75 PNF CZ	2
5	02289180	LIGHT,LICENSE PLATE W/BRKT	1
6	02290459	LIGHT,OVAL TAIL LED - KIT	2
7	08771174	AXLE,BASE BOOM ARM	2
8	08771282	DECAL,CONDUX APS75 4.50X 22.00	2
9	12000901	FLATWASHER,0.37 TYPEA-W-ST CZ	8
10	12013500	NUT,0.37-16 NYLOC ST GR5 CZ	4
11	21033937	TOOLBOX,TRAILER TONGUE	1
12	08771320	EXTENDABLE ARM	1
	08771150	FIXED STANDARD ARM	1

E. TRLR, APS-75 7500LB CABLE TRLR

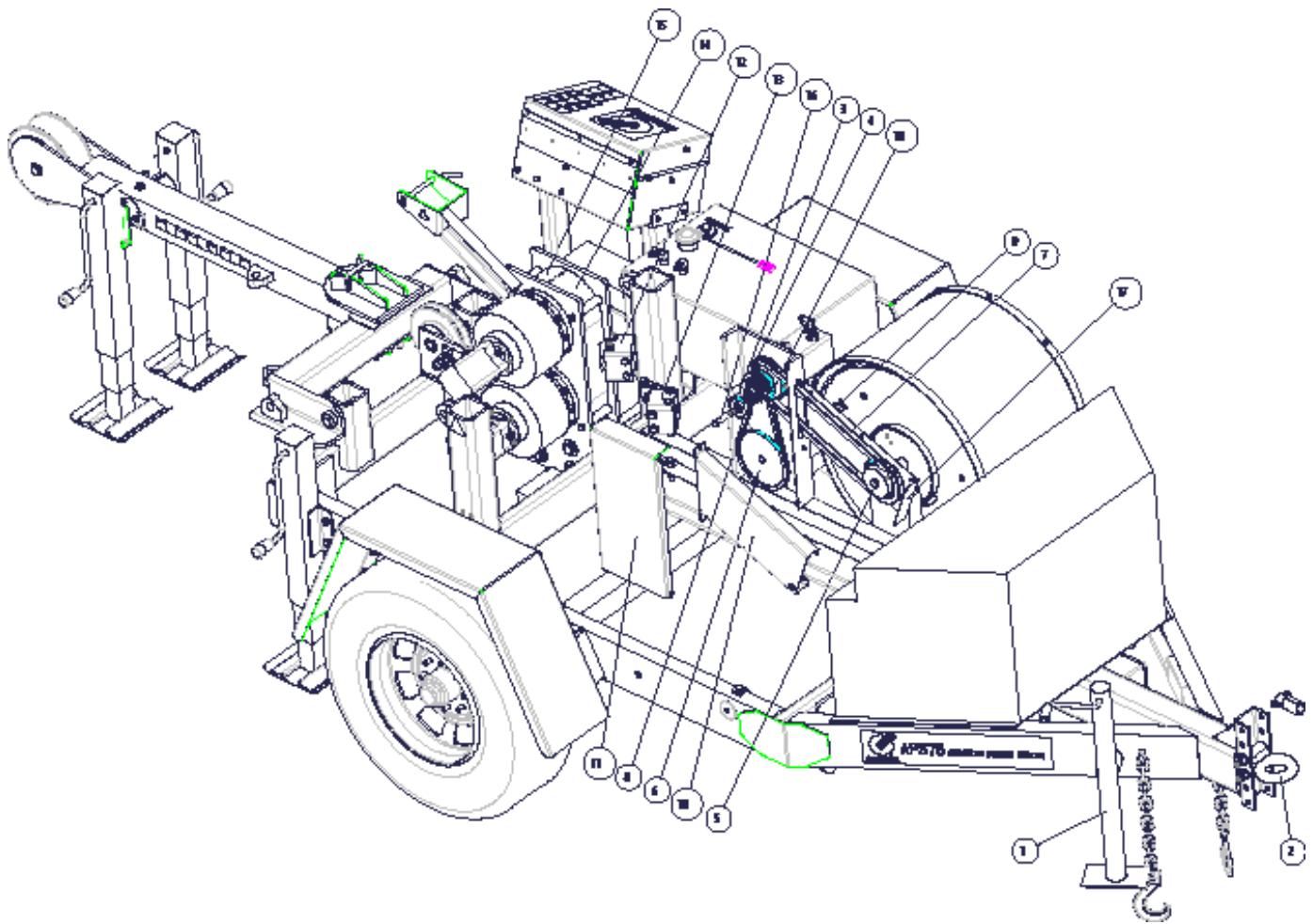

TRLR,APS---75 7500LB CABLE TRLR 08771000---

2

ITEM	PART NO	DESCRIPTION	QTY
1	02264100	JACK,SDEWND---PIPE MNT---2,000 15"	1
2	02265001	RING,ADJUSTABLE TOW --- PAINTED	1
3	02289571	SPROCKET,IDLER HB40A17	1
4	02290186	LINK,HALF #40---1/2PITCH SINGLE	1
5	02290302	SPROCKET, 60BS20 X 1.00 BORE	1
6	02290304	SPROCKET, 40BS46 X 3/4 BORE	1
7	02290305	CHAIN,#60---3/4PTCH 70 PTCHS SGL	1
8	02290306	CHAIN,#40---1/2PTCH 76 PTCHS SGL	1
9	02290588	LINK,HALF #60---3/4PITCH SINGLE	1
10	08771134	GUARD,CHAIN---TKUP REEL APS---75	1
11	08771135	GUARD,LVLWIND SPRKT APS---75	1
12	08771139	FAIRLEAD,CAPSTAN MOUNT APS---75	1
13	08771147	FAIRLEAD,MIDWAY GUIDE APS---75	1
14	08771165	GUARD,REAR---CAPSTAN SHLD APS---75	1
15	08771180	GUARD,FRONT---CAPSTAN SHD APS---75	1
16	08771189	SHAFT,IDLER LEVELWIND APS---75	1
17	08771190	GUARD,CHAIN---COVER APS---75	1

18	08771207	CLUSTER,SPKT---TKUPREEL APS---75	1
----	----------	----------------------------------	---

F. TRLR, APS-75 7500LB CABLE TRLR

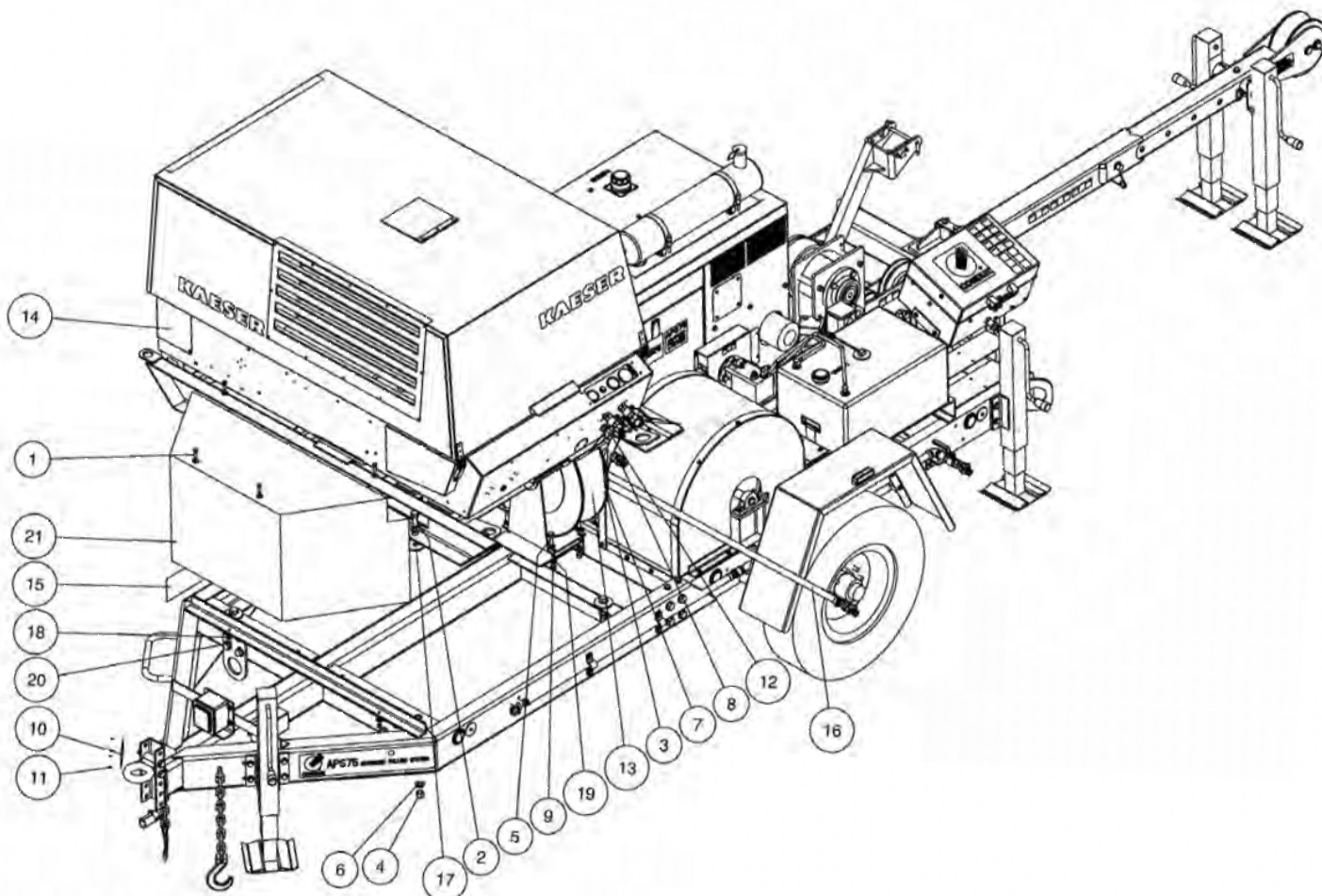

TRAILER PULLER APS-75 W/COMP ASSY 08771000-03

ITEM	PART NO	DESCRIPTION	QTY
1	02032000	CAPSCREW,0.37-16X1.25 HHSTGR8 YZ	4
2	02073300	CAPSCREW,0.75-10X2.00 HHSTGR8 YZ	4
3	02129710	CLIP,SAFETY-UNIVERSAL AIR CPLG	3
4	02200600	NUT,0.75-10 NYLOC ST GR5 CZ	4
5	02253600	CAPSCREW,0.50-13X1.75 HHSTGR5 CZ	4
6	02288518	FLATWASHER,0.75 TYPEA-N-ST CZ	8
7	02288876	LANYARD,ALL UNIVERSAL COUPLINGS	3
8	02289278	COUPLING,UNIVERSAL 3/4 FEMALE	1
9	02289478	NUT,0.50-13 NYLOC ST GR8 CZ	4
10	02289491	TAG,METAL VIN	1
11	02289504	SCREW,DRIVE #4 X 0.375 SS	4
12	02289856	FTG,HYD 12-NPT_M;12-NPT_F 90SW	2
13	02290641	REEL,HOSE .75" X 50' W/STOP	1
14	02291060	COMPRESSOR-DIESEL 185CFM-KAESER	1
15	08771282	DECAL,CONDUX APS75 4.50X22.00	2
16	08771290	HOSE,AIR PIPE SUPPLY	1
17	08771319	SPACER,KAESER COMP MTG	4
18	12000901	FLAT WASHER,0.37 TYPEA-W-ST CZ	8
19	12008301	FLAT WASHER,0.50 TYPEA-N-ST CZ	8
20	12013500	NUT,0.37-16 NYLOC ST GR5 CZ	4
21	21033937	TOOLBOX,TRAILER TONGUE	1

G. TRLR, APS-75 7500LB CABLE TRLR

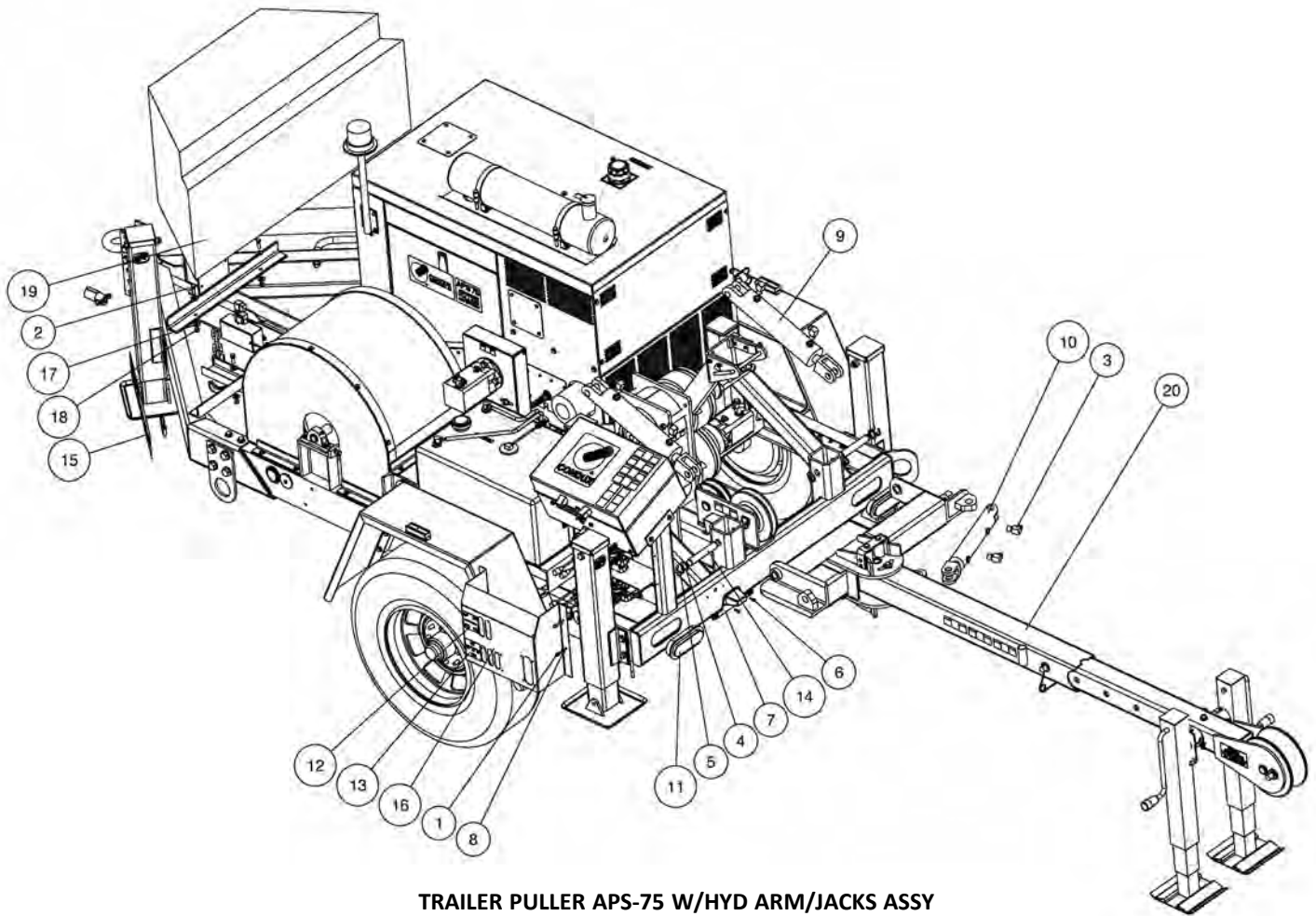

**TRAILER PULLER APS-75 W/HYD ARM/JACKS ASSY
08771000-05**

ITEM	PART NO	DESCRIPTION	QTY
1	02021400	CAPSCREW,0.25-20X0.75 HHSTGR5 CZ	4
2	02032000	CAPSCREW,0.37-16X1.25 HHSTGR8 YZ	4
3	02093600	FTG,HYD 08-NPT_M;08_M JIC 90	6
4	02204800	BEARING,THR 1.003-1.504-0.120	2
5	02222900	RING,RETAINING 1.000 EXT	4
6	02230401	SCREW,TAP .190-24X0.75 PNF CZ	2
7	02289180	LIGHT,LICENSE PLATE W/BRKT	1
8	02289411	LOCK WASHER,0.313 REGULAR ST CZ	4
9	02290406	CYLINDER,HYD-3000PSI 3.0BX10.0	2
10	02290407	CYLINDER,HYD-3000PSI 2.0BX6.0S	1
11	02290459	LIGHT,OVAL TAIL LED - KIT	2
12	02290615	LABEL,HYD ARM CONTROL	1
13	02290841	LABEL,HYD JACK CONTROL	1
14	08771174	AXLE,BASE BOOM ARM	2
15	08771282	DECAL,CONDUX APS75 4.50X 22.00	2
16	08771366	COVER,HYD CONTROL	1
17	12000901	FLATWASHER,0.37 TYPEA-W-ST CZ	8
18	12013500	NUT,0.37-16 NYLOC ST GR5 CZ	4
19	21033937	TOOLBOX,TRAILER TONGUE	1
20	SEE ARM ASSY	ARM,EXTENDED	1
	SEE ARM ASSY	ARM,STANDARD	1

I. TRLR, APS-75 7500lb CABLE TRLR

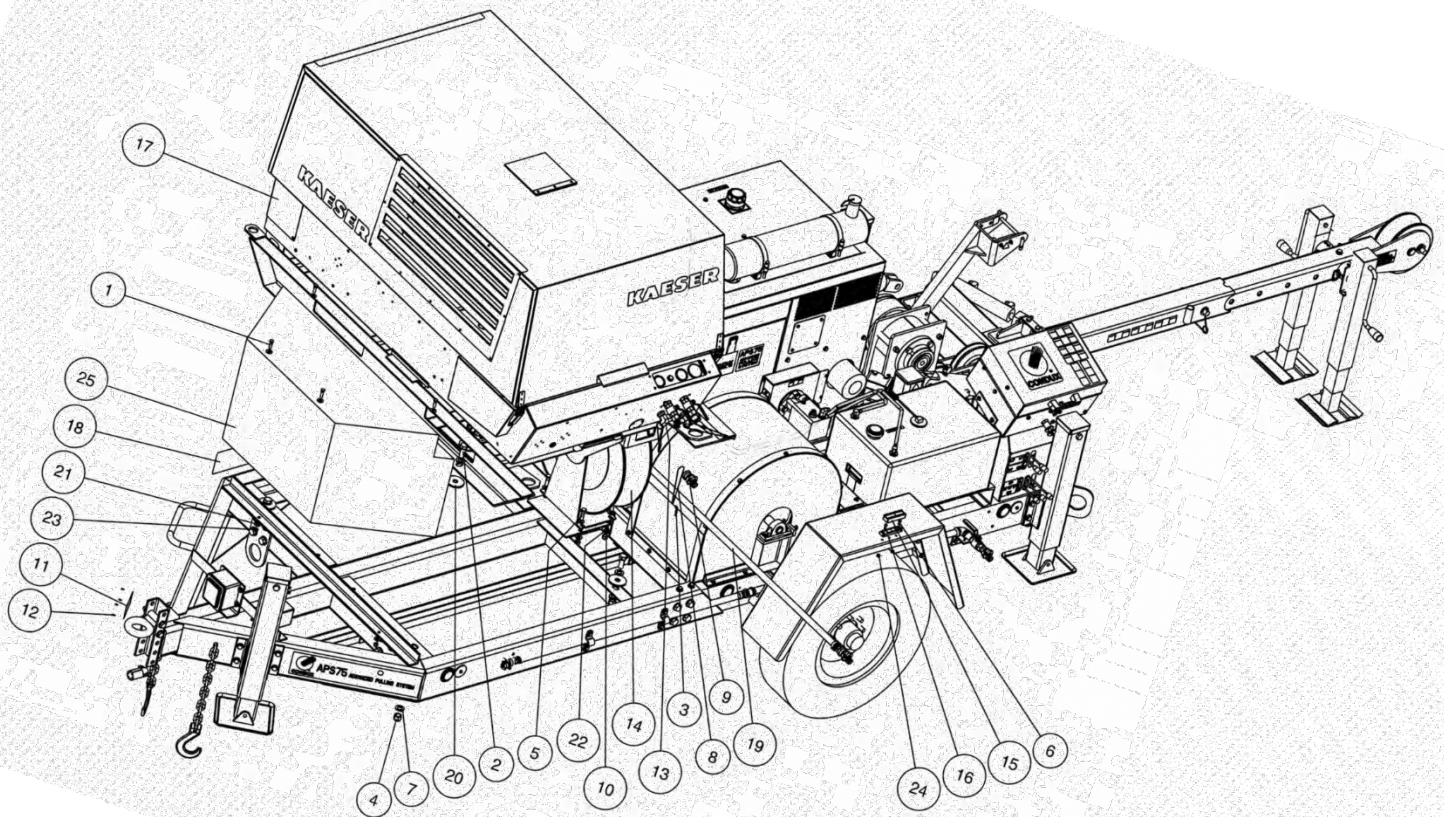

**TRAILER PULLER APS-75 W/COMP/HYD ARM/JACKS ASSY
08771000-06**

ITEM	PART NO	DESCRIPTION	QTY
1	02032000	CAPSCREW,0.37-16X1.25 HHSTGR8 YZ	4
2	02073300	CAPSCREW,0.75-10X2.00 HHSTGR8 YZ	4
3	02129710	CLIP,SAFETY-UNIVERSAL AIR CPLG	3
4	02200600	NUT,0.75-10 NYLOC ST GR5 CZ	4
5	02253600	CAPSCREW,0.50-13X1.75 HHSTGR5 CZ	4
6	02269699	CAPSCREW,0.25-20X0.75 BHSTALY PL	4
7	02288518	FLATWASHER,0.75 TYPEA-N-ST CZ	8
8	02288876	LANYARD,ALL UNIVERSAL COUPLINGS	3
9	02289278	COUPLING,UNIVERSAL 3/4 FEMALE	1
10	02289478	NUT,0.50-13 NYLOC ST GR8 CZ	4
11	02289491	TAG,METAL VIN	1
12	02289504	SCREW,DRIVE #4 X 0.375 SS	4
13	02289856	FTG,HYD 12-NPT_M;12-NPT_F 90SW	2
14	02290641	REEL,HOSE .75" X 50' W/STOP	1
15	02290883	LIGHT,FENDER MARKER, RED/AMB	2
16	02290887	MOUNT,FENDER LIGHT W/PLUG	2
17	02291060	COMPRESSOR-DIESEL 185CFM-KAESER	1
18	08771282	DECAL,CONDUX APS75 4.50X22.00	2
19	08771290	HOSE,AIR PIPE SUPPLY	1
20	08771319	SPACER,KAESER COMP MTG	4
21	12000901	FLATWASHER,0.37 TYPEA-W-ST CZ	8
22	12008301	FLATWASHER,0.50 TYPEA-N-ST CZ	8
23	12013500	NUT,0.37-16 NYLOC ST GR5 CZ	4
24	12013700	NUT,0.25-20 NYLOC ST GR5 CZ	4
25	21033937	TOOLBOX,TRAILERTONGUE	1

J. FAIRLE^A

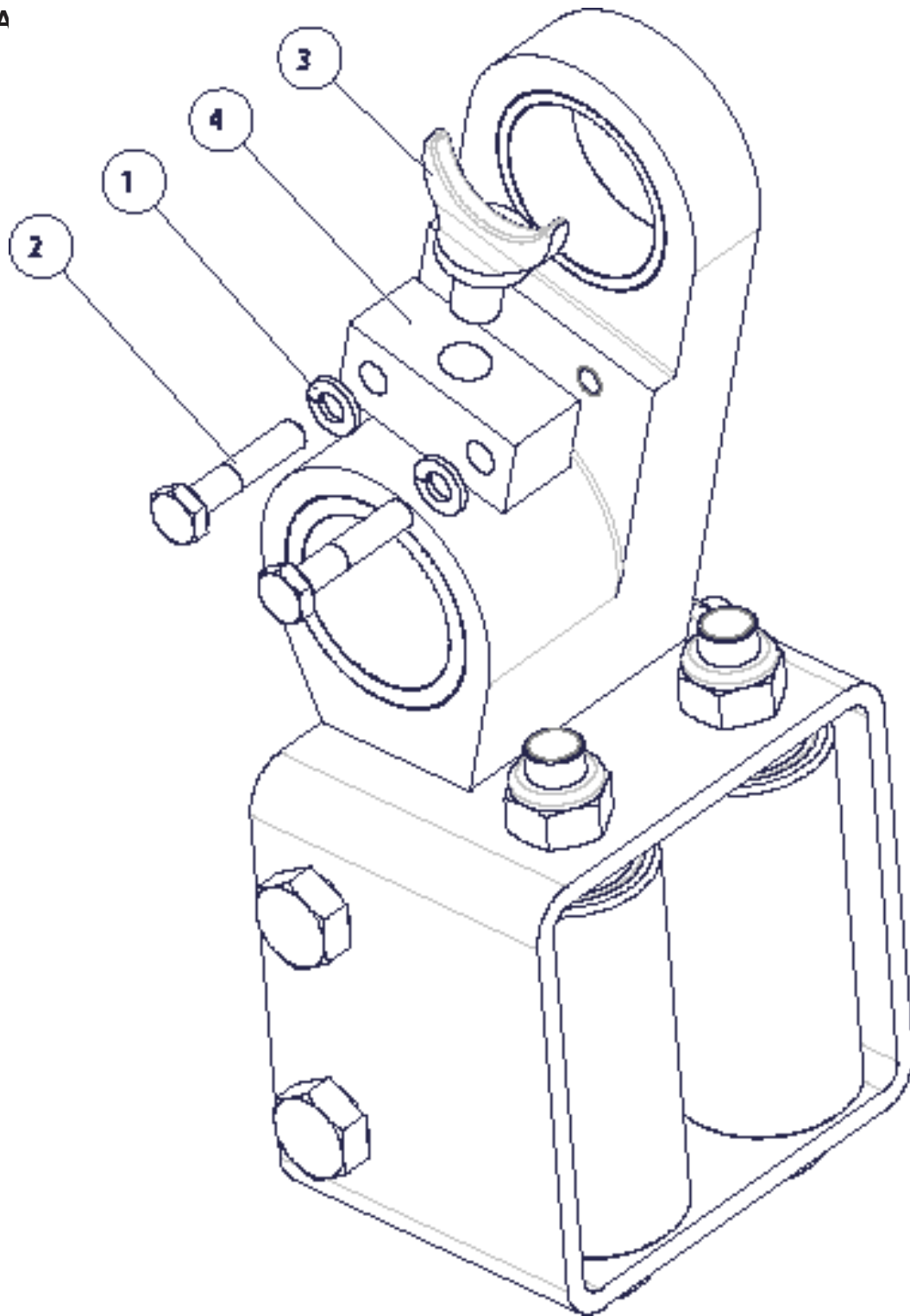

FAIRLEAD,LEVELWIND APS-75
08771122

ITEM	PART NO	DESCRIPTION	QTY
1	02021501	LOCKWSHR 0.25 REGULAR ST CZ	2
2	02288426	CAPSRW 0.25-20X1.25 HHSTGR5 CZ	2
3	21011189	PAWL,BRNZ FNGR D00-00197	1
4	21032472	BLOCK,LEVELWIND FINGER MNT	1

K. ARM, COMPLETE-ASSY APS-75

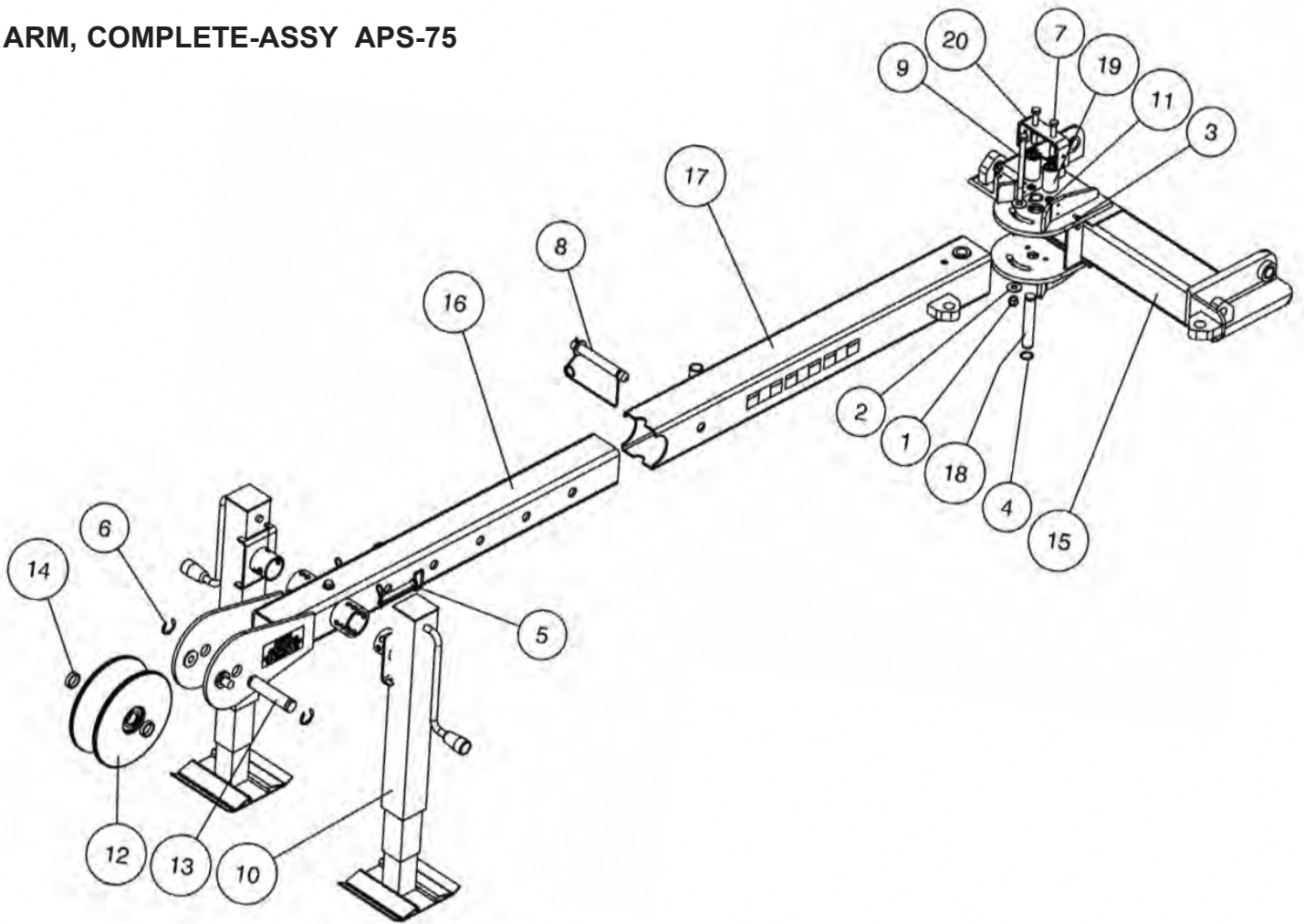

EXTENSION ARM,COMPLETE-ASSY APS-75
08771320

Item	Part No	Material Description	Quantity
1	02010100	NUT 0.50-13 NYLOC ST GR5 CZ	1
2	02021301	FLATWSHR 0.50 TYPEA-WIDE ST CZ	2
3	02168101	CAPSRW 0.25-20X0.50 HHSTGR5 CZ	4
4	02288243	RING,RETAINING 1.000 EXT(4100)	2
5	02289141	HITCH PIN - 1/2 X 4.0	2
6	02290577	RING,RETAINING 1.188 EXT E-RING	2
7	02290904	CAPSRW M12-1.75X 90 HHST8.8 CZ	2
8	02291018	PIN,SNAP LOCK .875 DIA X 5.50 LG	1
9	02291045	CAPSRW 0.50-13X7.00 HHSTGR5 CZ	1
10	08763155	JACK,BOOM ARM	2
11	08771125	SPACER,NYLON-ROPE GUIDE APS-75	4
12	08771158	SHEAVE,MAIN ROLLER-NYL APS-75	1
13	08771170	SHAFT,SHEAVE-MAIN RLR APS-75	1
14	08771258	TUBE,SPACER-MAIN ROLLER APS75	2
15	08771321	ARM,BASE ADJUSTABLE WELD APS-75	1
16	08771323	ARM,BOOM-EXT END-WELD APS-75	1
17	08771326	ARM,BOOM-BASE END-WELD APS-75	1
18	08771333	AXLE,PIVOT ARM-BOOM EXT APS-75	1
19	08771392	ROLLER,ASSY-FAIRLEAD APS-75	2
20	08771396	BRACKET,ROPE CONTAINMENT-APS75	1

L. ARM, BOOM PIVOT EXTENSN APS-75

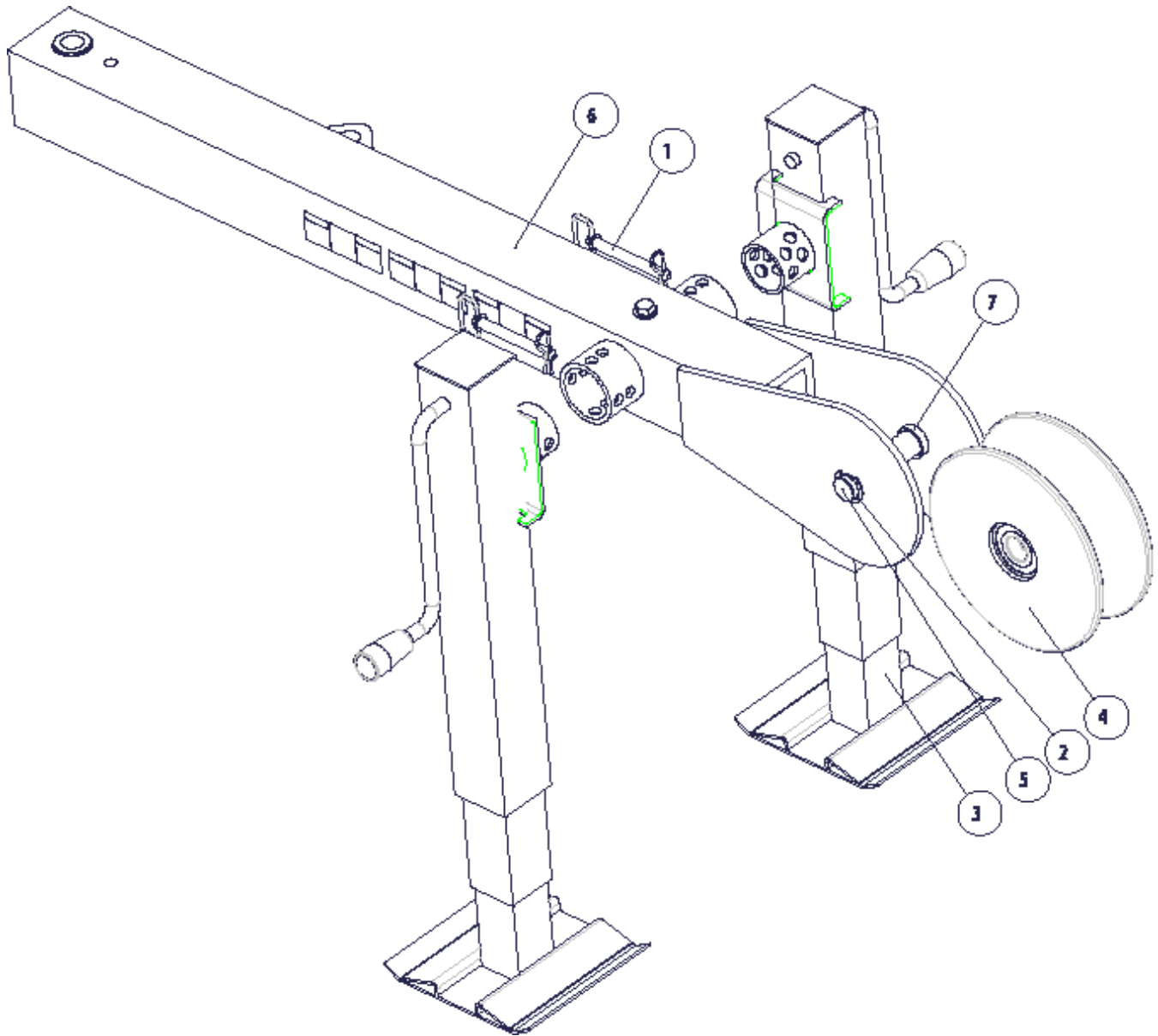

ARM,BOOM PIVOT EXTENSN APS---75
08771155

ITEM	PART NO	DESCRIPTION	QTY
1	02289141	PIN,HITCH .50" DIAM 4.0" GRIP	2
2	02290577	RING,RETAINING 1.188 EXT(1000)	2
3	08763155	JACK,505 BOOM ARMS---WELD	2
4	08771158	SHEAVE,MAIN ROLLER---NYL APS---75	1
5	08771170	SHAFT,SHEAVE---MAINRLR APS---75	1
6	08771224	ARM,BOOM---PIVOT END---ASSY---APS75	1
7	08771258	TUBE,SPACER---MAIN ROLLER APS75	2

M. CAP, ANTI SLOSH HYD FILLER

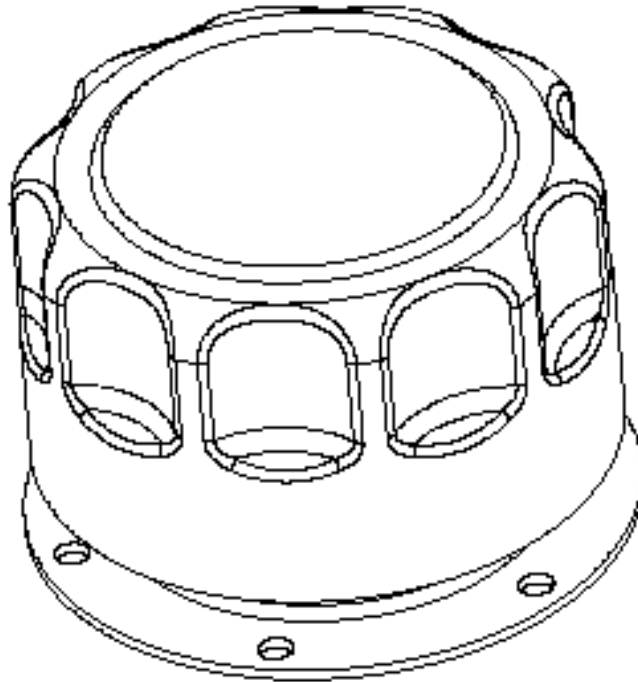

CAP,ANTI SLOSH HYD FILLER
02290602

ITEM	PART NO	DESCRIPTION	QTY
1	02290602	CAP,ANTI SLOSH HYD FILLER	1

N. PANEL, CONTROL-ASSEM-APS75

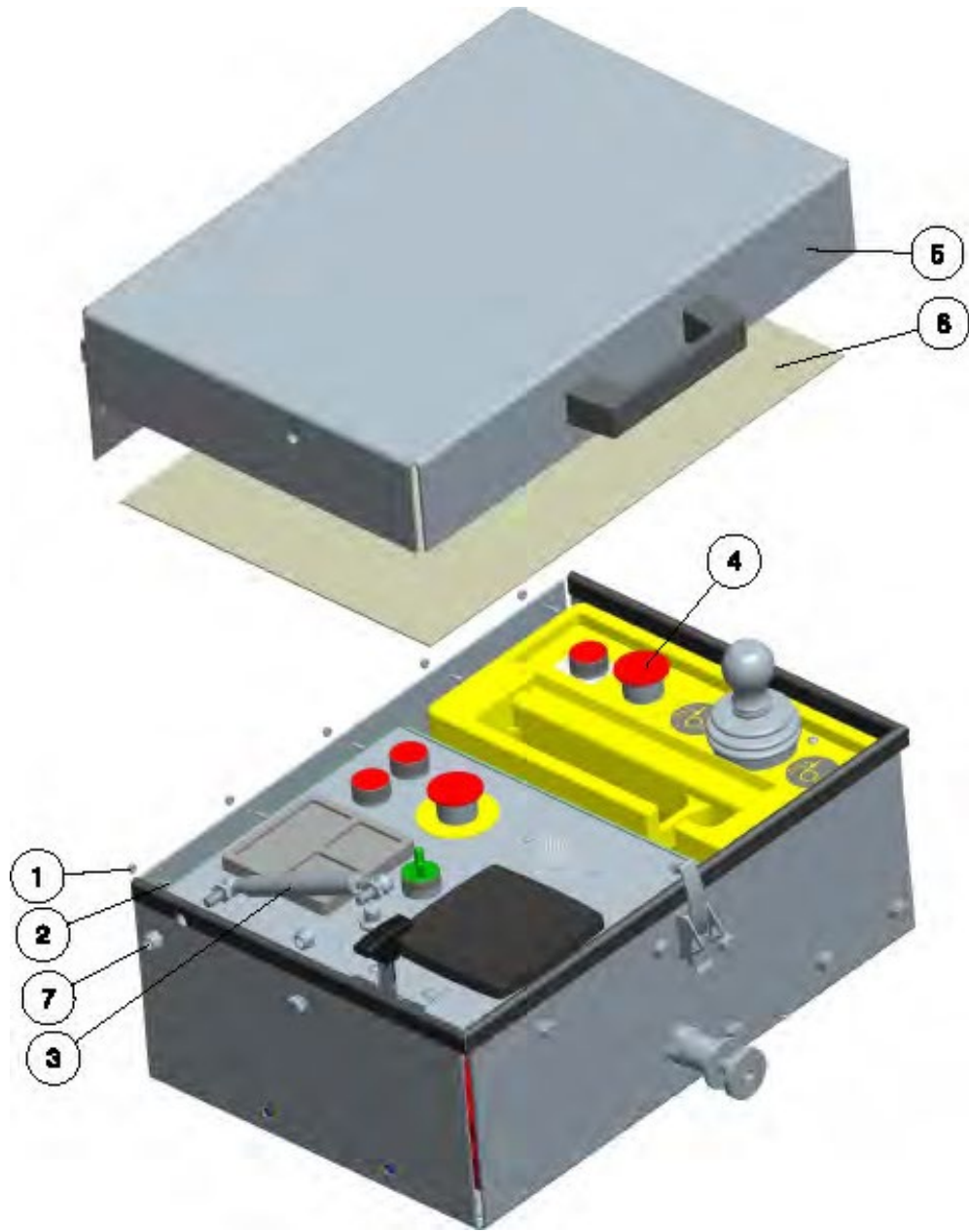

PANEL,CONTROL-ASSEM-APS75
08771040

ITEM	PART NO	DESCRIPTION	QTY
1	02290370	NUT #04-40 NYLOC ST GR2 CZ	5
2	02290375	CAPSRW #04-40X.31 BHSS 18-8	5
3	02290378	SPRING,GAS-15LBS 3.54" STROKE	1
4	08771053	CONTROL,REMOTE-ASSEY APS75	1

O. FAIRLEAD,CAPSTAN MOUNT APS-75

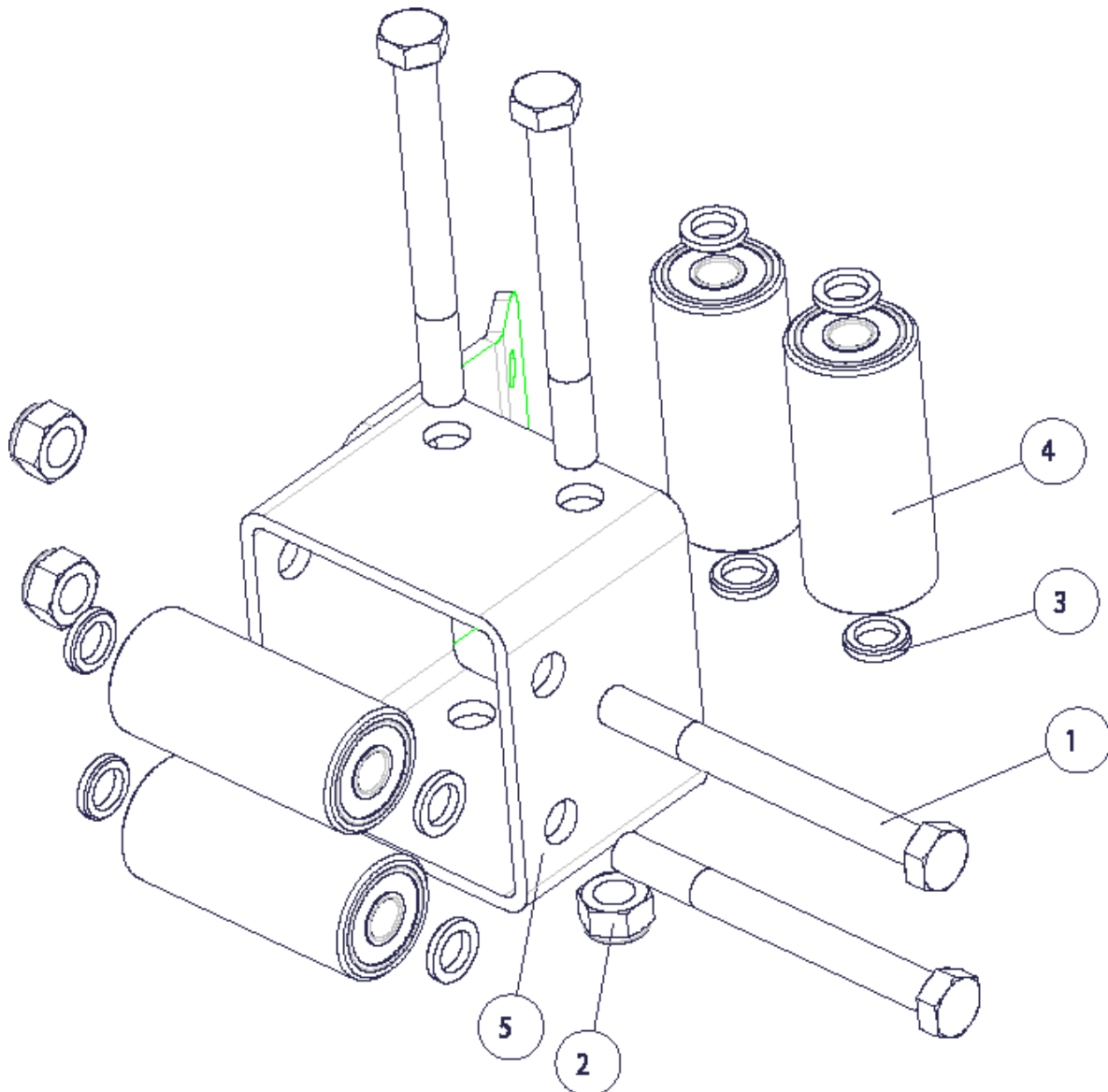

FAIRLEAD,CAPSTAN MOUNT APS-75
08771139

ITEM	PART NO	DESCRIPTION	QTY
1	02290380	CAPSRW M12-1.75X110 HHST8.8 CZ	1
2	02290381	NUT M12-1.75 NYLOC THN ST8.8CZ	4
3	08771125	SPACER,NYLON-ROPE GUIDE APS-75	8
4	08771138	ROLLER,ASSY-FAIRLEAD APS-75	4
5	08771219	FAIRLEAD,CAPSTAN-WELD APS75	4

P. FAIRLEAD,MIDWAY GUIDE APS-75

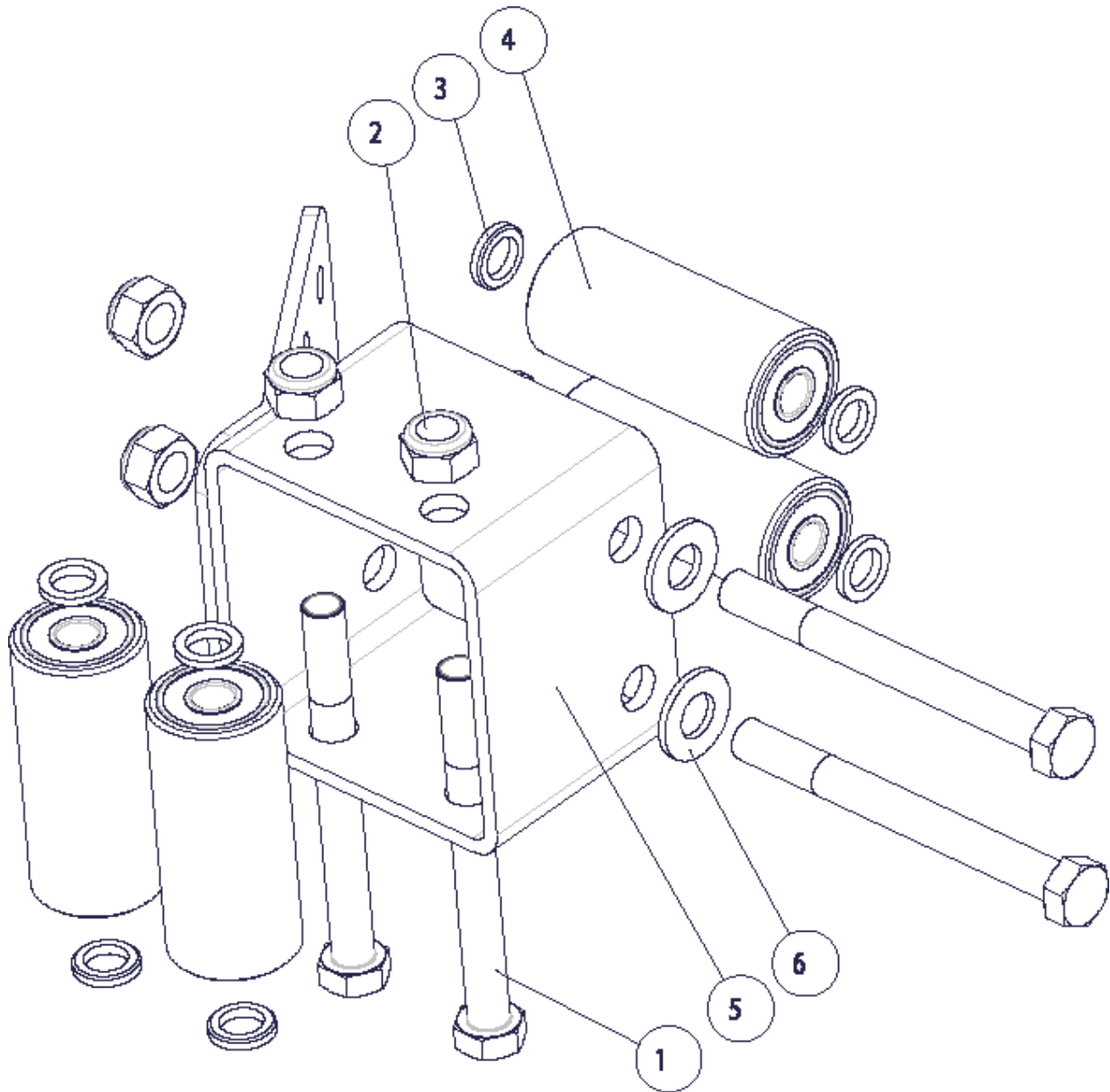

FAIRLEAD,MIDWAY GUIDE APS-75
08771147

ITEM	PART NO	DESCRIPTION	QTY
1	02290380	CAPSRW M12-1.75X110 HHST8.8 CZ	4
2	02290381	NUT M12-1.75 NYLOC THN ST8.8CZ	4
3	08771125	SPACER,NYLON-ROPE GUIDE APS-75	8
4	08771138	ROLLER,ASSY-FAIRLEAD APS-75	4
5	08771220	FAIRLEAD,MIDWAY-WELDMENT-APS75	1
6	12008301	FLATWSHR 0.50 TYPEA-NARR ST CZ	2

Warranty Information

12.

A. FACTORY ASSISTANCE

Condux International can provide further advice regarding any problems with the installation, service, assembly, or disassembly of the Condux Underground Puller. Call toll free at 1-800-533-2077 (USA and Canada) or 1-507-387-6576 and ask for assistance. The Condux Underground Puller can be returned to the factory at any time for service or repair; however, a Return Material Authorization (RMA) must be obtained from Condux before shipping. Condux will not accept returned items without an RMA.

B. LIMITED WARRANTY

Condux International, Inc. extends the following warranty to the original purchaser of these goods for use, subject to the qualifications indicated: Condux International, Incorporated warrants to the original purchaser for use that the goods or any component thereof manufactured by Condux International will be free from defects in workmanship for the period of one year from the date of purchase, provided such goods are installed, maintained, and used in accordance with Condux's written instructions.

Components not manufactured by Condux International but used within the assembly provided by Condux International are subject to the warranty period as specified by the individual manufacturer of said component, provided such goods are installed, maintained, and used in accordance with Condux's and the original manufacturer's written instructions.

Condux's sole liability and the purchaser's sole remedy for a failure of goods under this limited warranty, and for any and all claims arising out of the purchase and use of the goods, shall be limited to the repair and replacement of the goods that do not conform to this warranty.

To obtain repair or replacement service under the limited warranty, the purchaser must contact the factory for a Return Material Authorization (RMA). Once obtained, send the RMA along with the defective part or goods, transportation prepaid, to:
Condux International, Inc.
145 Kingswood Drive
Mankato, MN 56001 USA

THERE ARE NO EXPRESS WARRANTIES COVERING THESE GOODS OTHER THAN AS SET FORTH ABOVE. THE IMPLIED WARRANTIES OR MERCHANTABILITY AND FITNESS FOR A PARTICULAR PURPOSE ARE LIMITED IN DURATION TO ONE YEAR FROM DATE OF PURCHASE. CONDUX ASSUMES NO LIABILITY IN CONNECTION WITH THE INSTALLATION OR USE OF THIS PRODUCT, EXCEPT AS STATED IN THIS LIMITED WARRANTY. CONDUX WILL IN NO EVENT BE LIABLE FOR INCIDENTAL OR CONSEQUENTIAL DAMAGES.



®

CONDUX

Condux International, Inc.

P.O. Box 247 • 145 Kingswood Drive, Mankato, MN 56002-0247 USA 1-507-387-

6576 • 1-800-533-2077 • FAX 1-507-387-1442

Internet: <http://www.condux.com> • e-mail: cndxinfo@condux.com

© Copyright 2012, Condux International, Inc.

Printed in USA

Literature Part Number: 91000016

Revision Number: 1.1