

USER'S GUIDE & SAFETY MANUAL

Gulfstream™ 400 with Electrical Counter

Patent # 6264171

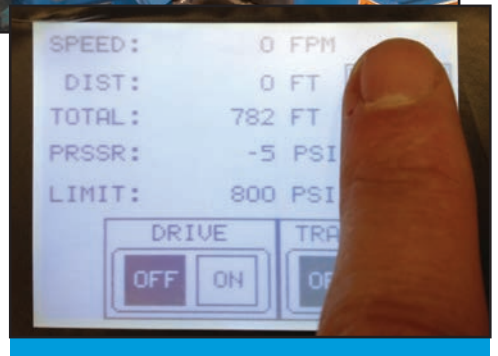
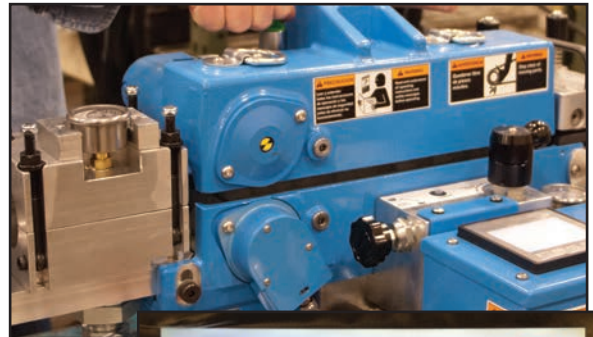

CONDUX

ISO 9001:2008
CERTIFIED

Important Safety Notice

Read and understand all procedures and safety instructions before using the Gulfstream™ 400. Observe all safety information on this page and note specific safety requirements as explained by procedures in this manual. Failure to follow these instructions could result in serious personal injury or death.

ADVERTENCIA:

Favor de leer y comprender todas las instrucciones de operación y seguridad antes de usar la máquina. Si Ud. no comprende las instrucciones favor de consultarle a su jefe.

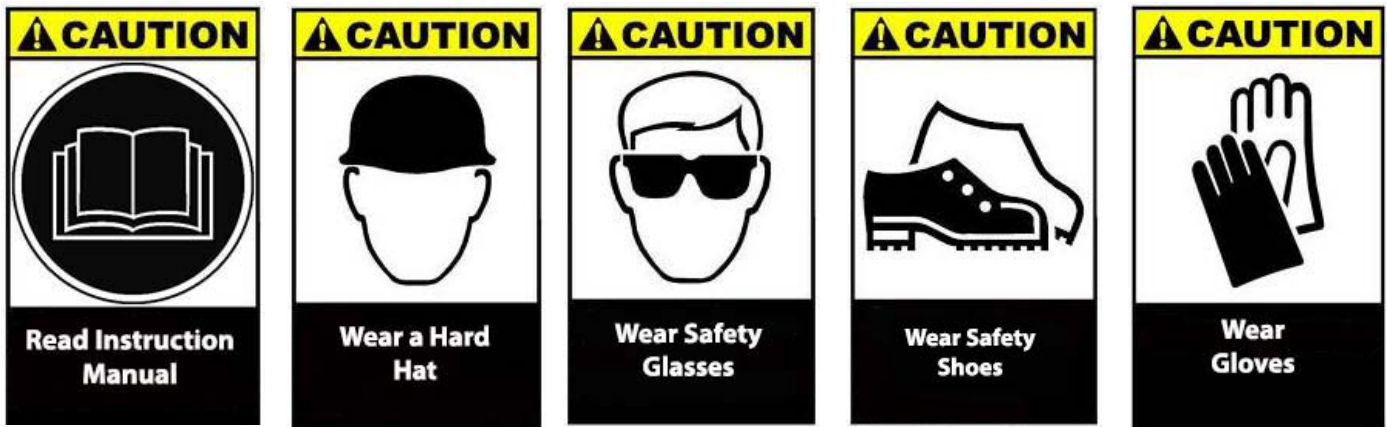

Save this user's guide for future reference.

COMMUNICATIONS WITH THE MANUFACTURER

For any information related to the machine (use, maintenance, spare parts) always state Model, Serial Number, Manufacturing Year and Order. This data can be found in the machine identification table.

Manufacturer:

Condux International Inc.

145 Kingswood Drive

Mankato, MN 56002-0247

1-507-387-6576

Fax 1-507-387-1442

Internet: <http://www.condux.com>

E-mail: cndxinfo@condux.com



CONDUX

If you have questions on:

SAFETY - OPERATIONS - APPLICATIONS

CALL 1-800-533-2077

Table of Contents

1	General Information	4
2	Technical Specifications	6
	A. Hydraulic	6
	B. Condition of Use	6
	C. Air Compression Requirements	6
	D. Operational Capacities	8
	E. Electronic Control Box	8
	F. Physical Specifications	8
	G. Acoustic Emission	8
	H. Caterpillar Drive Specifications	8
	I. Conduit Coupling Requirements	8
3	Safe Operating Procedures	9
	A. Work Area Safety	9
	B. Hydraulic Devices	9
	C. Pneumatic Devices	9
	D. Electric Devices	10
4	Unpacking the Gulfstream™400	10
	A. Blower Components	10
	B. Tools and Materials	10
5	Set Up the Blower	11
	A. Attach Blower to Job Box	11
6	Cable Crash Test	12
7	Pressure Test Conduit	17
8	Prepare Conduit for Cable	22
9	Prepare Cable	25
10	Final Set-Up	27
	A. Final Inspection	28
11	Blower Operating Instructions	28
	A. Observer at Exit Pit	28
	B. Connect Hydraulic Systems	28
	C. Set up the Electronic Control Box	29
	D. Panel Layout	30
	E. Traction Control	32
	F. Operation	32
12	Tear Down Procedures	34
	A. Remove Power from Unit	34
	B. Remove Cable from Blower	35
	C. Separate Unit from Conduit	35
13	Maintenance	36
	A. Track Cleaning & Tightening	36
	B. Replacement of Drive Belt	36
14	Troubleshooting Guide	38
15	Appendices	39
	A. Blower with Job Box	39
	B. Upper Drive Shaft Replacement Kit	40
	C. Lower Drive Shaft Replacement Kit	41
	D. Hydraulic Motor Replacement Kit	42
	E. Idler Bracket Bushing & Idler Bracket Screw Replacement Kits	43
	F. Air Block Assembly Replacement Kits	44
	G. Counter Clamp Roller & Cable Guide Replacement Kits	46
	H. Timing & Takeup Roller & Idler Roller Replacement Kits	47
	I. Hydraulic Coupler (Male) Replacement Kit	48
	J. Hydraulic Coupler (Female) Replacement Kit	49
	K. Clamp Adjustment Replacement Kit	50
	L. Lower Counter Roller Replacement Kit	51
	M. RH Cable Guide Roller Replacement Kit	52
	N. LH Cable Guide Roller Replacement Kit	53
	O. Counter Spring Replacement Kit	54
	P. Base Mount	55
	Q. Pneumatic & Electrical Circuits	56
	R. Hydraulic Circuit	57
	S. Hydraulic Flow Control Valve	58
	T. Possible Wear & Replacement Parts & Accessories	59
16	Warranty Information	67

General Information

1.

The operating instructions contain a full description of the Gulfstream™400, which has been designed for the purpose of feeding fiber optic cable through round conduits of uniform cross section. The conduit must previously have been installed underground or overhead to receive the fiber optic cable and must be of sufficient length on exit to be received by the machine. The conduit must be made of material with sufficient compression strength for it to be adequately sealed in the exit of a machine. The conduit must be airtight up to a pressure of 175 psi (12 bar). For this purpose, connectors of screw, compression or fusion type must be used. Conduits from (10 mm) to 1.97" (50.00 mm) and fiber optic cables from 1/4" (6 mm) to 1.13" (28.7 mm) diameter can be accepted by the machine.

Fiber optic cable is fed into the conduit by combining pulling and pushing forces, which draw the fiber optic cable through the conduit. The pulling force is achieved by connecting the leading end of the fiber optic cable to a piston or carrier, which fits exactly into the conduit to make an airtight seal. Air under pressure is fed in behind the carrier causing it to be forced through the conduit. As the carrier moves through the conduit, it pulls the fiber optic cable behind it. The fiber optic cable is continuously pushed into the conduit by a tractor drive. This consists of two caterpillar tracks, which grip the top and bottom of the fiber optic cable moving it into the conduit. This ensures the fiber optic cable is always free as it moves into the conduit and reduces the magnitude of the pulling forces needed to carry the leading end through. Special lubricants are used to make it easier for the carrier to pass through the conduit.

The exit of the machine consists of an air box that is made in two halves that clamp together. The air box contains special removable seals on entry and exit, which clamp around either the end of the conduit or the fiber optic cable to be fed into the conduit. The seals can be changed to accommodate different conduit and fiber optic cable sizes. The conduit is clamped between a pair of seals at the entrance to the air block. A clamp located in front of the entrance to the air block holds the conduit mechanically to prevent it from moving axially. The fiber optic cable enters through two seals located in an aluminum nozzle that splits in half. The aluminum nozzle is located in the entrance to the air box and is shaped to ensure an airtight seal around the fiber optic cable. When the two halves of the air box are closed, air pressure is admitted into the space between the seals on entry and exit.

The use of the Gulfstream™400 for operations different from those discussed in this manual are considered extremely dangerous and thus forbidden. The use of the Gulfstream™400 for purposes other than the one's described in this manual will result in improper use and relieves the manufacturer from any responsibility, civil or penal. The manufacturer's responsibility declines even when one of the following happens:

- a. The consequences caused by tampering and/or modifications carried out without the manufacturer's written acceptance.
- b. The use of imitative spare parts.
- c. Bad maintenance.
- d. Use with disconnected safety devices.
- e. The connection to machine and/or parts not produced and not directly authorized by the manufacturer in a written acceptance.

Designed to reduce stress on the fiber optic cable during installation The Gulfstream™ 400 is a unique device intended for inserting fiber optic cable directly into conduit with out the use of pull tape and pulling machines.

Comprised of an air block and a tractor drive that, when combined with an air compressor and a hydraulic power unit, will propel fiber optic cable measuring from ¼" to 1.13" (6 mm to 28.7 mm) into an unobstructed, unoccupied, airtight conduit run at speeds of 0 to 300 feet per minute (0-91 m/min). A cable carrier must be placed at the front end of the cable.

The Gulfstream™400 comes standard with job box, hydraulic hoses with couplings, digital LCD electronic counter box, and an adjustable control valve to the tractor drive for speed adjustment.

GENERAL MACHINE USE

- a. Only qualified operators should use the machine. The operator should only be the person who received qualified training from the product owning company or trained by the manufacturer.
- b. Machine must only be used for the work it was designed for.
- c. Machine is not to be used with unauthorized personnel on the job site.
- d. Should there be any doubt concerning use, functioning, maintenance or anything else, please contact the factory or factory representative.

OPERATOR QUALIFICATIONS

- a. Operator must know the required safety directives to run the machine that are pertinent to the country where it is being used.
- b. Operator in charge of the machine and installation project must be appropriately dressed, avoiding large clothes, hanging jewelry or whatever might become entangled in the moving parts.
- c. Operator must also wear the necessary protective equipment such as gloves, boots, helmet, etc.
- d. Operator must carefully follow all advisements contained in the instruction manual or on the machine.
- e. Operator must have work area kept clean of obstacles that might inhibit a safe working area.

MAINTENANCE QUALIFICATION

- a. All of the machine maintenance must be carried out with the machine on a level surface and not attached to any form of power source: electrical, pneumatic, nor hydraulic.
- b. Authorized and trained personnel must do all maintenance operations. Trained personnel are defined as people who have received qualified training from the using company or from the manufacturer.

Technical Information

2.

A. HYDRAULIC SYSTEM REQUIREMENTS

- Hydraulic Operating Pressure: 1500 psi (103 bar) maximum
- Hydraulic Flow: 6.8 gpm (20.8 l/m) maximum
- Hydraulic Circuit Type: Open Center
- 5 micron filtration
- Fitted with BHTMA standard 1/2" flat faced quick release couplings
- Proper sized power unit should be used to run the blower machine to prevent overheating

IMPORTANT: Operators must take any precautions that may have been recommended by the suppliers of lubricants or hydraulic fluids. This applies to the use and disposal of lubricants and hydraulic fluids including the lubricant used to ease the passage of fiber optic cables through conduits.

B. CONDITION OF USE

Temperature from 21° F (-6° C) to 110° F (+43° C)

Humidity from 30% to 90% +/- 5%

Weather conditions relevant to working conditions

Natural and/or artificial lighting of the work site, minimum 200 lux

C. AIR COMPRESSOR REQUIREMENTS

- Pneumatic Pressure: 175 psi (12 bar) Maximum
- Required Flow Capacity: 375 SCFM (11 m³/min) Maximum
- Conduit Size: 10 mm-1.97" (50 mm) OD
- Air coolers are recommended for blowing fiber
- Compressor flow may need to be doubled if blowing distance is greater than 3,500 feet (1,067 meters)
- Air hose fittings need to be compatible with Dixon "Air King" universal couplings.

The following charts help to determine the compressor size requirement based on testing the conduit system (Figures 1-3).

1. Pressurize the conduit up to the maximum compressor pressure. That is the P_{start} - value.
2. Time for 10 seconds and record the ending pressure, P_{end}.
3. Subtract P_{start}-P_{end} and divide by 10.
4. Find the appropriate x value and approximate length of conduit run then correlate that information with the size of the conduit on the graph. The resulting zone is the approximate compressor requirement.

D. OPERATIONAL CAPACITIES

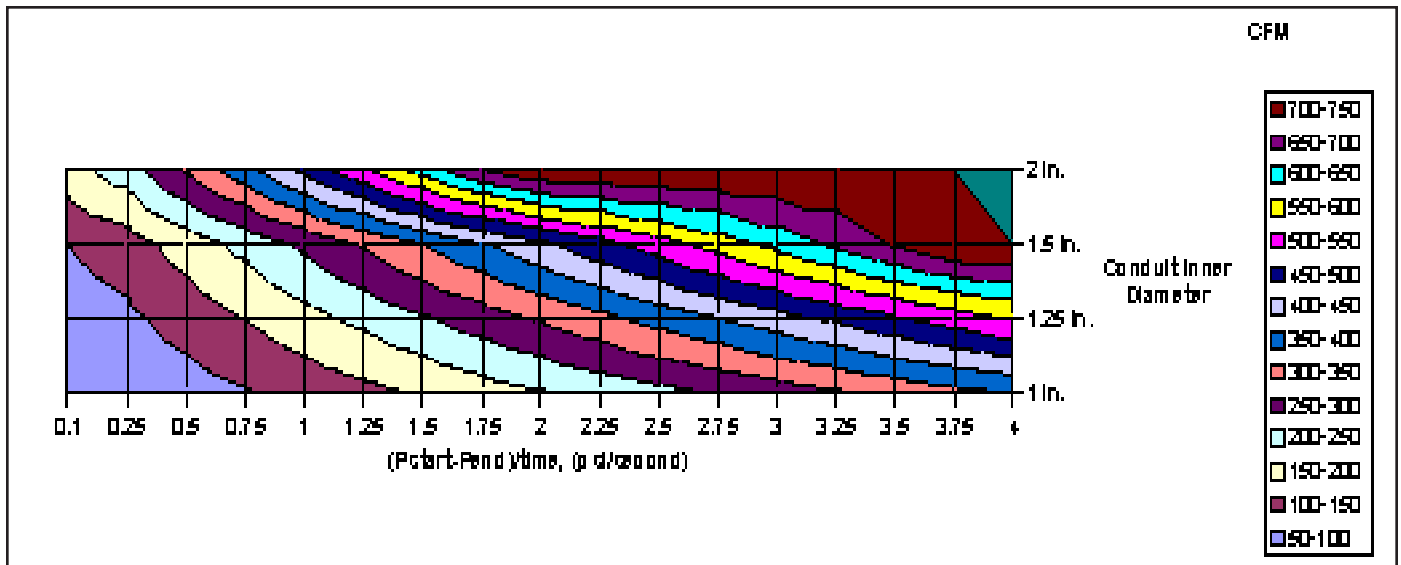

Figure 1. Compressor Sizing for 3,280 ft (1,000 m) of Conduit Run

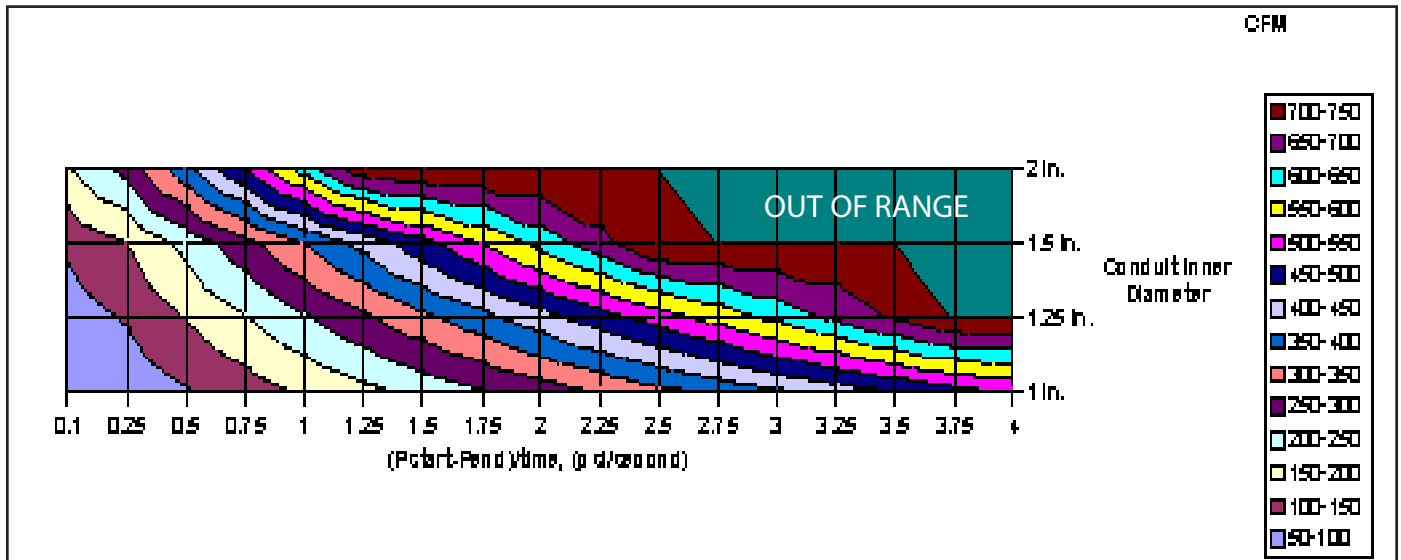

Figure 2. Compressor Sizing for 4,921 ft (1,500 m) of Conduit Run

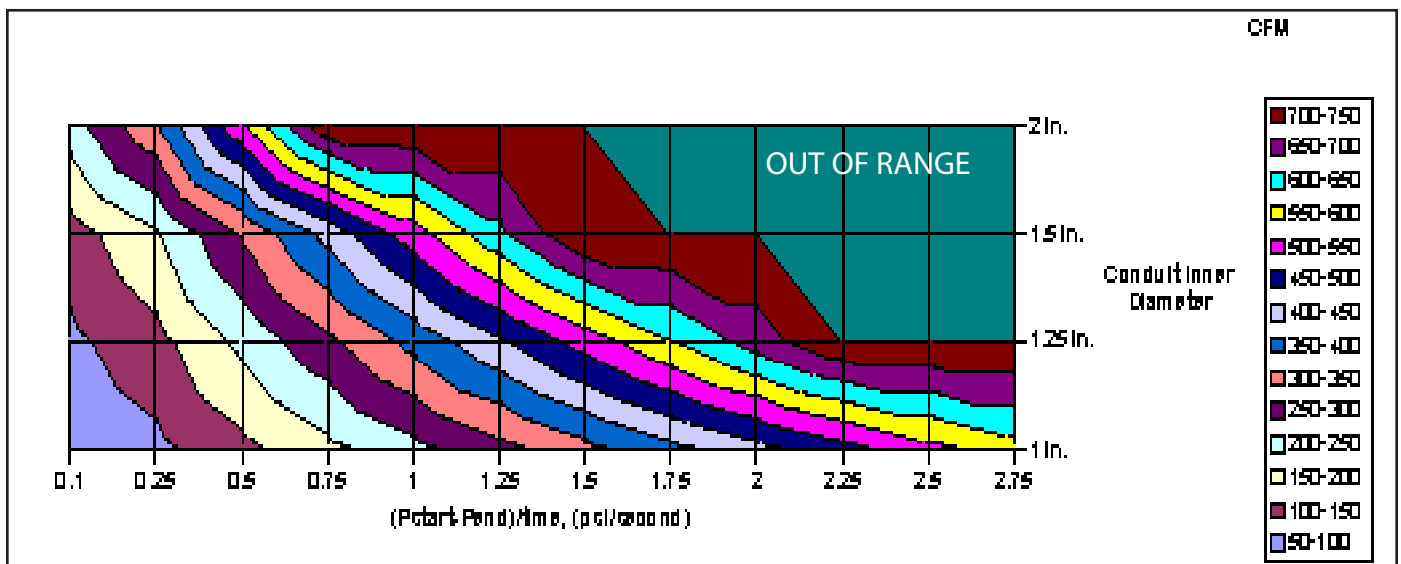

Figure 3. Compressor Sizing for 8,202 ft (2,500 m) of Conduit Run

- Pushing Force: 175 lbs (778 N) maximum
- Pushing Speed: 300 ft/min (91 m/min) maximum
- Cable Sizes: .25" to 1.13" (6 mm to 28.7 mm)
- Conduit Sizes: 1/2", 3/4", 1", 1-1/4" TRUE, 1-1/4", 1-1/2" SDR 11 & 13.5, 2" and metric O.D. conduit; 10 & 12 mm, 12.7 mm, 14 mm, 16 mm, 18 mm, 25 mm, 32 mm, 36 mm, 37 mm, 40 mm, 42 mm, 44 mm, 46 mm and 50 mm

E. ELECTRONIC CONTROL BOX

- Power Requirements: 12 volts DC
- Power consumption is 24 Watts
- Power connection must be to automotive power point or power point connection on Condux hydraulic power unit
- Fused with a 2.5 amp fuse, 250 volt-5x20mm-GMA type
- Displays: Total Machine Distance, Distance of Run, Operational Speed, Errors Descriptions
- Automatic Shutdown Speeds: 300 ft/min (91 m/min) maximum

F. PHYSICAL SPECIFICATIONS (DOES NOT INCLUDE LEGS OR JOB BOX)

- Height 16.5" (419 mm)
- Length 30" (761 mm)
- Width 14.8" (375 mm)
- Weight 82 lbs (37 kg)

G. ACOUSTIC EMISSION

- Level of max. sound pressure to the operator seat (ISO 11202) $L_{ep}=85$ dB(A)

H. CATERPILLAR DRIVE SPECIFICATIONS

- Maximum pushing force: 175 lbs (778 N), depending on cable diameter
- Maximum pushing speed: 300 ft/min (91.5 m/min)
- Maximum clamping force: <114 lbf/in (20 N/mm)
- Independent pushing drive belts with polyurethane pads profiled for cable 0.23" (5.8 mm) to 1.13" (28.7 mm)
- Mechanical gas charged shock absorber clamp to prevent cable crush.
- Side guards.

I. CONDUIT COUPLING REQUIREMENTS

- Must withstand maximum air pressure of 175 psi (12 bar).
- Must withstand axial loading and vibration.
- Must be screw type, compression type, or fusion type.
- Sight Holes must be sealed.
- Must fit snugly.
- Conduit ends must be cut off squarely and deburred.
- Conduit must be fully seated into the coupler.
- Couplers should be installed in a straight section of conduit.
- Must be same size as conduit.

Safe Operating Practices

3.

Read and understand all procedures and safety instructions before using the Gulfstream™ 400. Observe all safety information on this page and note specific safety requirements as explained by procedures called out in this manual. Failure to follow these instructions could result in serious personal injury, property damage or death.

A. WORK AREA SAFETY

1. Wear personal protective equipment: hard hat, safety glasses, safety shoes, and leather work gloves.
2. The safe operation of this equipment requires that the operators be on stable footing.
3. Stay clear of cables or lines under tension.
4. Stay clear of pressurized line and conduit.
5. Stay out of manhole while blower is in use.
6. Use the blower only for its intended purpose. Do not use the tractor drive without the air block to push or pull cable.
7. Do not place cable reel too close to unit. Place the reel far enough away from the unit to ensure proper control.
8. Do not tamper with relief valves or pressure reducing valves.
9. Place cable grip on end of conduit to catch cable carrier and cable.
10. Keep hands away from tractor drive while blower is in operation.

B. HYDRAULIC DEVICES

Escaping fluids under pressure can penetrate the skin and cause serious personal injury. Observe the following precautions to avoid hydraulic hazards:

1. Tighten all connections before applying pressure. Relieve pressure when connecting or disconnecting hoses when servicing the unit.
2. Check for leaks with a piece of cardboard. Do not use your hands!
3. Do not exceed working pressure of hydraulic hoses.
4. Visually inspect hoses regularly and replace if damaged.

C. PNEUMATIC DEVICES

The Gulfstream™ 400 is a pneumatic device, using pressurized air to project cable at high velocities. Please observe the following precautions when operating the blower:

1. Forced air creates flying debris. Always wear personal protective equipment. Severe personal injury could result.
2. Ensure no personnel are in the destination access vault during the blowing operation. Severe personal injury could result.

D. ELECTRIC DEVICES

The electronic counter box and power supply are electrical devices. Electric shock hazards exist that could result in severe personal injury or death. Observe the following precautions to avoid electrical hazards:

1. Do not operate in or near water. This includes setting the electronic counter box or battery pack on a wet surface or exposing them to rain.
2. Do not remove cover of electronic counter box. There are no user-serviceable parts inside. Refer servicing to qualified service personnel.
3. The electronic counter box power switch should be in the off position before connecting or disconnecting any cords.

Unpacking the Blower

4.

A. BLOWER COMPONENTS

Each Gulfstream™ 400 Package contains the following items.

- Hydraulic hose from hydraulic control assembly to hydraulic power unit
- Owner's Manual
- Shipping Crate
- Metric & Standard Allen Wrench Set
- $\frac{3}{8}$ " Drive Ratchet & $\frac{9}{16}$ " Deep Well Socket
- $\frac{5}{8}$ " x 600 lb. Swivel
- Venturi Air Plug
- Plastic Divided Case w/Parts Label
- Parts and User Manual
- 1 Qt. Blowing Lubricant
- Capscrew Set (10) (M04-0.7's)
- O-Ring Seal Kit

NOTE: If any parts are missing: please contact your Condux representative or call Condux International at 1-800-533-2077 (USA or CANADA), or 1-507-387-6576.

B. TOOLS AND MATERIALS REQUIRED

The tools and materials are necessary to connect the Gulfstream™ 400 to a hydraulic power source, and to change the inserts:

1. Allen Wrench ($\frac{3}{32}$ ")
2. Allen Wrench (2.5 mm)
3. Allen Wrench (5 mm)
4. Screwdriver, Flat
5. Screwdriver, Phillips
6. $\frac{3}{8}$ " Drive Ratchet
7. $\frac{9}{16}$ " Deep Well Socket

Set Up the Blower

5.

This manual contains setup and operating instructions for the Gulfstream™400 with job box.

IMPORTANT: The Deluxe Blower must not be located below overhead gantries, power lines or walkways where there might be a risk of falling objects. The operator must be wearing recommended protective gear before operating the blower. Operating light levels should be at least 200 lux of light intensity.

CAUTION

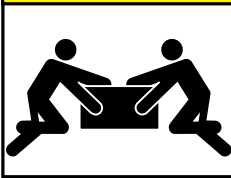

A. ATTACH BLOWER TO JOB BOX

CAUTION: The machine should be removed with two people or lifted mechanically by the lift rings located on the top of the machine (Figure 4).

IMPORTANT: The Gulfstream™400 should not be parked on a slope in excess of 13°. It should not be parked on a side hill of more than 15°.

Remove the ball detent pin from the bottom of the blower. Attach the Gulfstream™400 to the job box by aligning the guide tracks on the bottom of the blower with the channel on the top of the box. Holes in the box channel need to align with holes on the blower guide track. Once aligned, replace ball detent pin so it locks the blower in place (Figure 5).

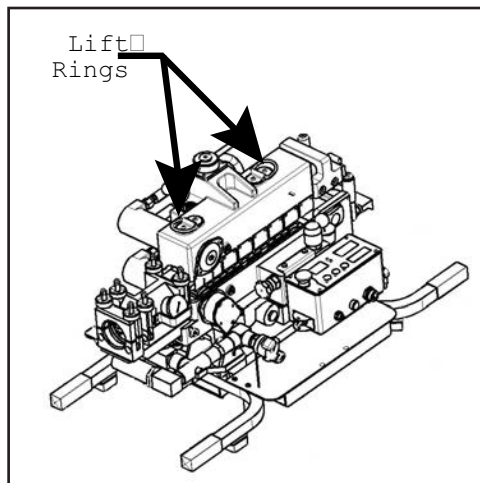

Figure 4. Lift out Blower with Lift Rings

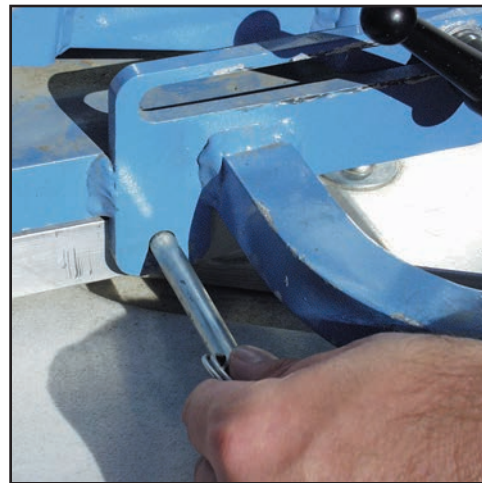

Figure 5. Replace Ball Detent Pin

Cable Crash Test

Cable Crash Testing is a very quick and easy step to be completed before attempting the installation of cable with the Gulfstream™400. This test is necessary to set the hydraulic motor pressure of the blower below the point that it may cause cable damage as a result of over pushing or encountering an obstruction in the sub-duct system.

Every cable has different pushing values and these values vary depending on duct I.D. Example: A cable with a crash test value of 75 bar in 33 mm I.D. duct, may have a crash value of only 60 bar in a 40 mm I.D. duct. This is because the area of lateral movement is larger as the duct size increases.

!CAUTION: Always wear protective equipment: hard hat, safety glasses, safety shoes and work gloves.

NOTE: The hydraulic motor pressure adjustment will have no effect on the installation speed of the blowing unit. This is not a flow adjustment. This is a pressure adjustment to prevent damage to the cable that can be caused by excessive pushing force.

IMPORTANT: For the Crash Test to work properly use the same size cable and duct that will be used for the job.

Set the hydraulic motor pressure on your Gulfstream™400 using the following procedure.

1. Attach 12' (4 m) of duct to the Gulfstream™400 (Figure 6).
2. Install Conduit Pulling Eye on the receiving end of the duct (Figure 7).



Figure 6. Placement of Conduit in Conduit Seal & Conduit Clamp



Figure 7. Installing Conduit Pulling Eye

3. Cut a piece of fiber optic cable 15' (5 m) long. This is your test piece of cable.
4. Attach the correct size Venturi to fit the cable being installed (Figure 8).

6.





Figure 8. Install Venturi

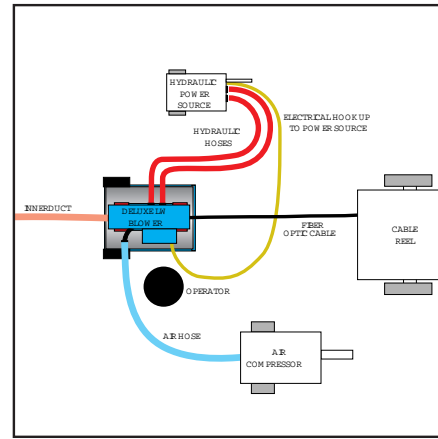

Figure 9. Typical Set-Up

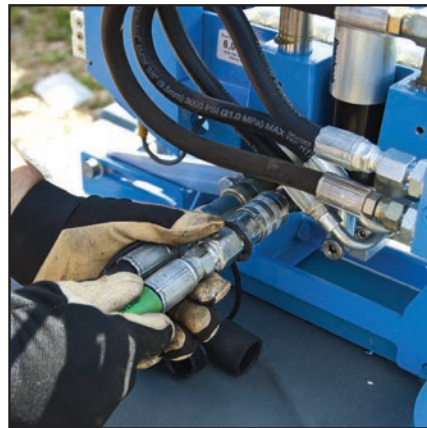

Figure 10. Attach Hydraulic Hoses

5. Attach Hydraulic Hoses (Figure 9). The Gulfstream™400's hydraulic system uses quick-disconnect couplings. Keep all connections clean to avoid contamination and possible system failure. Use hose end caps (supplied). A contaminated hydraulic system will effect the operation of the cable blower and may invalidate your product warranty. Take caution in routing the hoses to prevent a tripping hazard. Follow these steps to connect the hydraulic components:

A. Attach the quick-disconnect couplings to the hydraulic powersupply (Figure 10).

B. Start the hydraulic power unit and check all connections for leaks with a piece of cardboard. In cold weather, run hydraulic power supply until hydraulic oil warms up.

WARNING: Escaping fluids under pressure can penetrate the skin and cause serious personal injury. Observe the following precautions to avoid hydraulic hazards:

- Tighten all connections before applying pressure. Relieve pressure before connecting or disconnecting hoses.
- Check for leaks with a piece of cardboard. Do not use hands!
- Do not exceed working pressure of hydraulic hoses. Visually inspect hoses regularly and replace if damaged.

C. Run the blower for approximately 1 minute to remove any trapped air and then stop the blower and hydraulic power source.

ELECTRONIC CRASH TEST

To run the Crash Test utilizing the Electronic Control Boxes PRESSURE LIMIT feature, follow Crash Test steps 1-5 to set up the blower.

6. Press Touch Screen "LIMIT: XXXX" to open the Limit keypad.
7. Enter the desired pressure – suggested starting point is 800 PSI.
8. Place Cable in Blower from Rear Rollers through Tractor Drive. Push cable through the duct until it stops against the Pulling Eye (Figure 13).

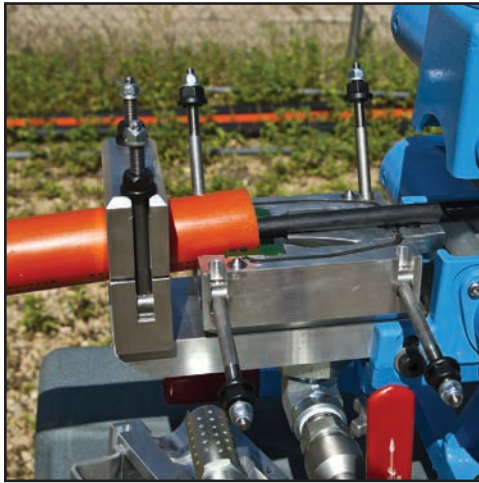

Figure 13. Install Cable



Figure 14. Mark the Cable

9. Place a mark on the Cable about 2" (51 mm) behind the Rear Rollers (Figure 14).
10. Install top Venturi (Figure 15). Close Air Block and tighten (Figure 16).

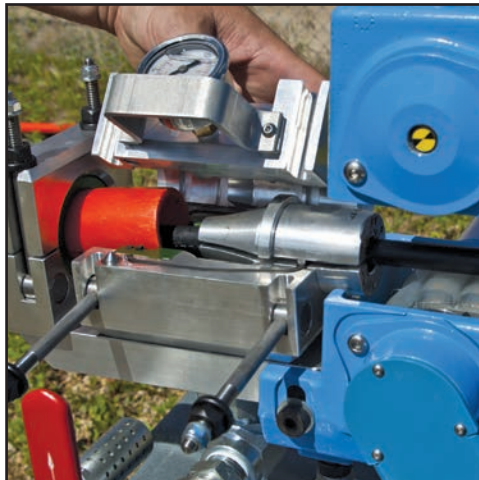

Figure 15. Install Top Venturi

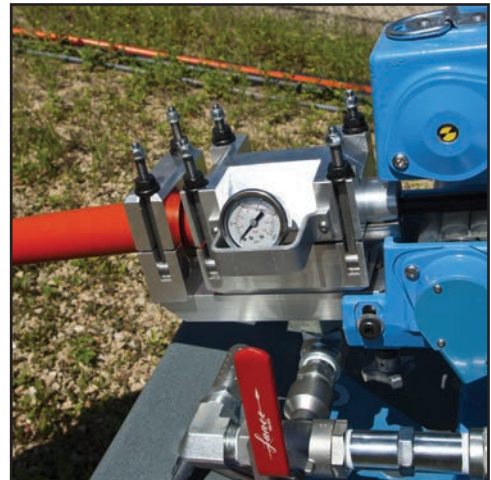

Figure 16. Close Air Block and tighten

11. From the Rear Rollers, pull out approximately 8' (2.4 m) of cable from the blower.
12. To avoid start up pressure spikes, which will register on the pressure transducer and produce a false pressure error, set the Hydraulic Flow Control to the lowest speed by rotating the flow control knob clockwise until it stops.

13. Lower the Tractor Drive Cover, and tighten until the tracks make contact with the cable. Give one additional turn to the clamp screw.
14. Turn on Hydraulic Power, and press the ECB DRIVE button ON.
15. Increase speed as quickly as possible by turning the Hydraulic Flow Control counter-clockwise. The Cable should be pushed into the duct. Continue to speed up the tracks until the cable stops and the ECB gives a HI-PRESSURE ERROR screen.
16. If a HI-PRESSURE ERROR appears, follow the on-screen instructions to reset the electronics and return to the Operations screen.
17. Raise Tractor Drive Cover. Pull out 8' (2.4m) of cable from the blower.
18. Lower and tighten Tractor Drive Cover. Repeat steps 6-7 to increase the pressure by 50 PSI.
19. Repeat steps 12-16 until cable damage is seen – either in the form of jacket damage or bends in the cable, the cable folds over, or you reach 1500 psi. You will notice cable fold-over because the line drawn on the cable will disappear inside the machine or duct. (Figure 17).

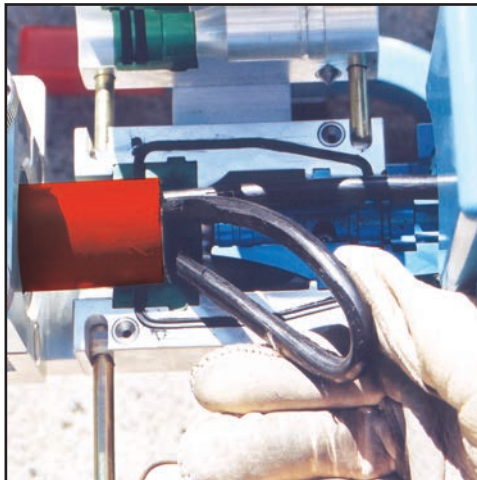

Figure 17. Cable folds over

20. Repeat steps 6 and 7 to reduce the PRESSURE LIMIT by 50 PSI.
21. Remove folded fiber and test again at current PRESSURE LIMIT settings to ensure no fiber fold over or damage occurs.
22. Remove test piece of fiber optic cable.
23. If the re-test confirms no cable damage, Re-adjust Flow Control setting to the slowest speed.
24. Remove test duct piece from the Deluxe Blower.
25. Crash test is complete.

Pressure Test Conduit

7.

The conduit system must be able to withstand a maximum pressure of 175 psi, and be free of leaks. A Conduit Pressure Test Kit, part number 08761457, is available to perform this test. Conduit may also be tested for pressure using the Gulfstream™400, follow the steps below.

1. Loosen the 6 nuts on the Air Block assembly (Figure 20). Open the Conduit Clamp Cover and Air Block Cover (Figure 21).

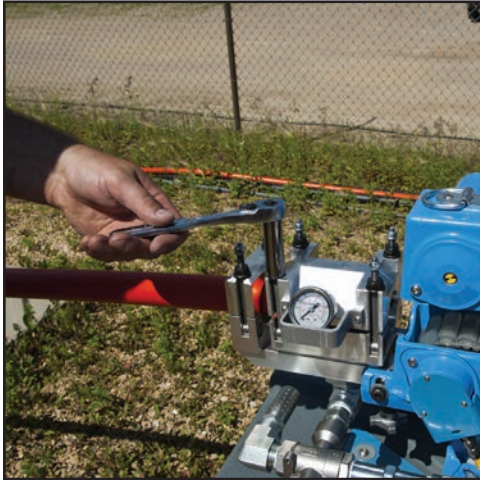

Figure 20. Loosen Air Block Assembly

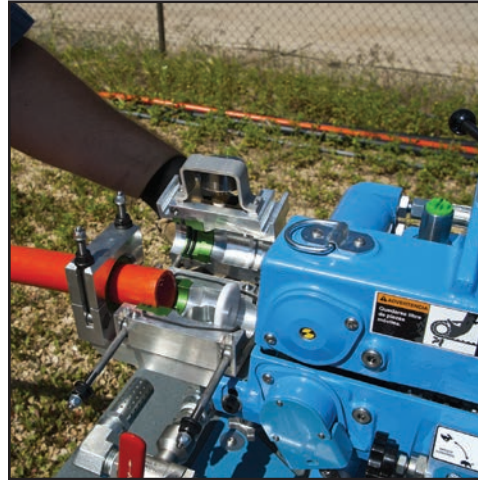

Figure 21. Open Conduit Clamp Cover & Air Block Cover

2. Select the correct Conduit and Cable Components according to conduit and cable size. Refer to the Conduit and Cable Pack selection charts (Tables 1 and 2, page 18).
3. Choose the correct Conduit Seal and install both halves securely. (Figure 22).
4. Choose the correct Conduit Clamp and install both halves (Figure 23).

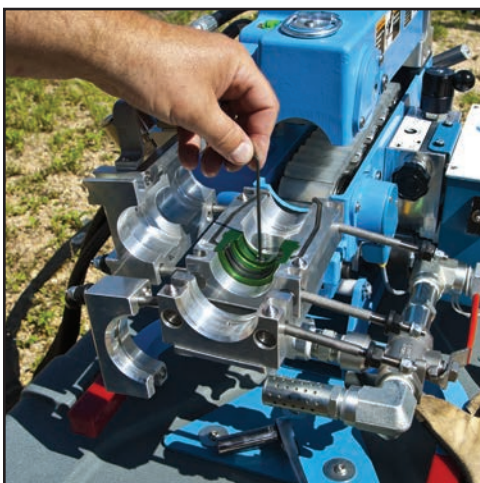

Figure 22. Install Conduit Seal

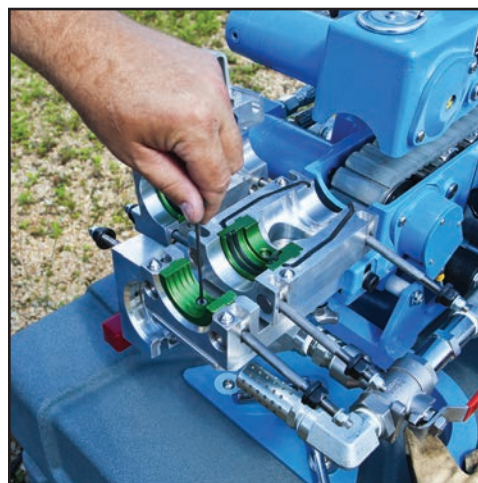

Figure 23. Install Conduit Clamp

PACKAGE	CABLE PACK		VENTURI		CABLE SEAL		CABLE GRIP	
	P/N	Cable OD	P/N	Cable OD	P/N	Cable OD	P/N	Cable OD
		Inch/mm		Inch/mm		Inch/mm		Inch/mm
1	08780393	0.23-0.34 (5.8-8.8)	08780281	0.23-0.34 (5.8-8.8)	08780406	0.23-0.28 (5.8-7.2)	08643754 033-29-1194	0.21-0.35 (5.3-8.9)
					08780407	0.29-0.34 (7.3-8.8)		
2	08780394	0.35-0.60 (8.9-15.2)	08781115	0.35-0.48 (8.9-12.2)	08761424	0.35-0.42 (8.9-10.7)	08643755 033-29-1195	0.32-0.48 (8.1-12.2)
					08761425	0.43-0.48 (10.8-12.2)		
			08781116	0.49-0.60 (12.3-15.2)	08761426	0.49-0.55 (12.3-14.0)	08643756 033-29-1196	0.42-0.61 (10.7-15.5)
					08761427	0.56-0.60 (14.1-15.2)		
3	08780395	0.61-0.85 (15.3-21.6)	08780284	0.61-0.73 (15.3-18.5)	08761428	0.61-0.67 (15.3-17.0)	08643757 033-29-1197	0.53-0.74 (13.5-18.8)
					08761429	0.68-0.73 (17.1-18.5)		
			08780285	0.74-0.85 (18.6-21.6)	08761430	0.74-0.79 (18.6-20.1)	08643758 033-29-1198	0.64-0.87 (16.3-22.1)
					08761431	0.80-0.85 (20.2-21.6)		
4	08780396	0.86-1.13 (21.7-28.7)	08780286	0.86-0.97 (21.7-24.6)	08761432	0.86-0.92 (21.7-23.4)	08643759 033-29-1199	0.75-1.00 (19.1-25.4)
					08761433	0.93-0.97 (23.5-24.6)		
			08780446	0.98-1.13 (24.7-28.7)	08761434	0.98-1.04 (24.7-26.4)	08643137 033-03-013	1.00-1.24 (25.4-31.5)
					08761435	1.05-1.13 (26.5-28.7)		

Table 1. Cable Packs

PACKAGE	DUCT PACK		DUCT CLAMP		DUCT SEAL		CARRIE		FOAM CARRIER		CABLE GRIP		INNERDUCT EYE	
	P/N	Duct Size	P/N	Duct OD	P/N	Duct OD	P/N	Carrier	P/N	Carrier OD	P/N	Duct OD	P/N	ID Range
		Inch/mm		Inch/mm		Inch/mm		Inch/mm		Inch/mm		Inch/mm		Inch/mm
1	08780795	0.50" SDR 11-13.5	08780791	0.84 (21.30)	08780786	0.84 (21.30)	08780793	0.688 (17.50)	08078300	0.75 (19.0)	08643131 033-03-012	.75-.99 (19-25)	08761840	.76-.87 (20-22)
2	08780680	0.75" SDR 11-13.5	08780682	1.050 (26.6)	08780685	1.050 (26.6)	08780690	0.75 (19.0)	08078300	0.75 (19.0)	08643137 033-03-013	1.00-1.24 (25.4-31.5)	08761840	.71-.89 (16-22)
3	08780386	1.00" SDR 11-13.5	08780369	1.315 (33.4)	08780307	1.315 (33.4)	08761250	1.121 (28.5)	08761439	1.25 (31.8)	08643149 033-03-016	1.00-1.24 (25.4-31.5)	08761842	1.06-1.43 (27-37)
4	08780392	1.25" SDR 11-13.5	08780375	1.660 (42.2)	08780051	1.660 (42.2)	08761255	1.414 (35.9)	08761440	1.50 (38.1)	08643149 033-03-016	1.50-1.99 (38.1-50.5)	08761842	1.06-1.43 (27-37)
5	08780397	1.50" SDR 11-13.5	08780404	1.900 (48.3)	08780398	1.900 (48.3)	08761260	1.618 (41.1)	08761441	1.75 (44.5)	08643149 033-03-016	1.50-1.99 (38.1-50.5)	08761844	1.37-1.68 (35-43)
6	08780930	2.00" SDR 11-13.5					08761265	2.023 (51.4)	08761442	2.00 (50.8)	08643155 033-03-017	2.00-2.49 (50.8-63.2)	08761846	2"
7	08781120	20mm	08781122	0.787 (20.0)	08781121	0.787 (20.0)	08780793	0.688 (17.5)	08761444	1.00 (25.4)	08643131 (033-03-012)	.75-.99 (19.0-25.1)	08914007	.551-.813 (14-20.65)
8	08780240	25mm	08780099	.984 (25.0)	08780134	0.984 (25.0)	08780230	0.787 (20.0)	08761439	1.25 (31.8)	08643137 033-03-013	1.00-1.24 (25.4-31.5)	08761840	.71-.89 (18-22)
9	08780385	32mm	08780368	1.260 (32.0)	08761560	1.260 (32.0)	08761560	1.063 (27.0)	08761439	1.25 (31.8)	08643143 033-03-15	1.25-1.49 (31.8-37.8)	08761842	1.06-1.43 (27-37)
10	08780387	36mm	08780370	1.417 (36.0)	08761643 08761555	1.417 (36.0)	08761643 08761555	1.181 (30.0) 1.220	08761439	1.25 (31.8)	08643143 033-03-15	1.25-1.49 (31.8-37.8)	08761842	1.06-1.43 (27-37)
11	08780388	37mm	08780371	1.457 (37.0)	08761555	1.457 (37.0)	08761555	1.220 (31.0)	08761439	1.25 (31.8)	08643143 033-03-15	1.25-1.49 (31.8-37.8)	08761842	1.06-1.43 (27-37)
12	08780389	1.25" TRUE	08780372	1.500 (38.1)	08761670	1.500 (38.1)	08761670	1.250 (31.0)	08761440	1.50 (38.1)	08643143 033-03-15	1.25-1.49 (31.8-37.8)	08761842	1.06-1.43 (27-37)
13	08780390	40mm	08780373	1.575 (40.0)	08761579	1.575 (40.0)	08761579	1.299 (33.0)	08761440	1.50 (38.1)	08643149 033-03-016	1.50-1.99 (38.1-50.5)	08761842	1.06-1.43 (27-37)
14	08780391	42mm	08780374	1.653 (42.0)	08761660	1.653 (42.0)	08761660	1.378 (35.0)	08761440	1.50 (38.1)	08643149 033-03-016	1.50-1.99 (38.1-50.5)	08761842	1.06-1.43 (27-37)
15	08780545	44mm	08780546	1.732 (44.0)	08761786	1.732 (44.0)	08761786	1.496 (38.0)	08761440	1.50 (38.1)	08643149 033-03-016	1.50-1.99 (38.1-50.5)	08761842	1.06-1.43 (27-37)
16	08780575	50mm	08780435	1.969 (50.0)	08761579	1.969 (50.0)	08761579	1.606 (40.8)	08761442	2.00 (50.8)	08643149 033-03-016	1.50-1.99 (38.1-50.5)	08761844	1.37-1.68 (35-43)

Table 2. Conduit Packs

5. Choose the correct Venturi to fit the cable being installed. Do not install at this time!
6. Place conduit in the Conduit Seal and Conduit Clamp. Note placement up to ridge on Conduit Seal (Figure 24).
7. Clamp conduit in place (Figure 25).

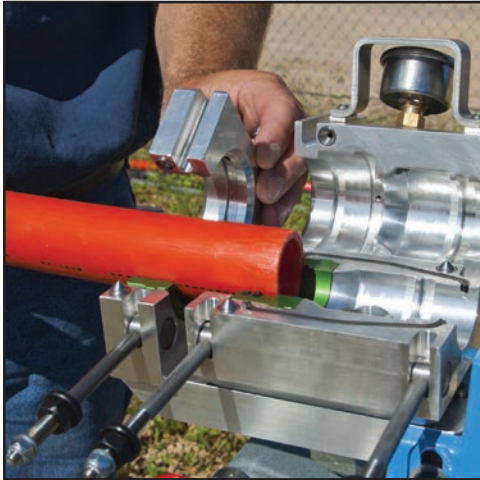

Figure 24. Placement of Conduit in Conduit Seal & Conduit Clamp

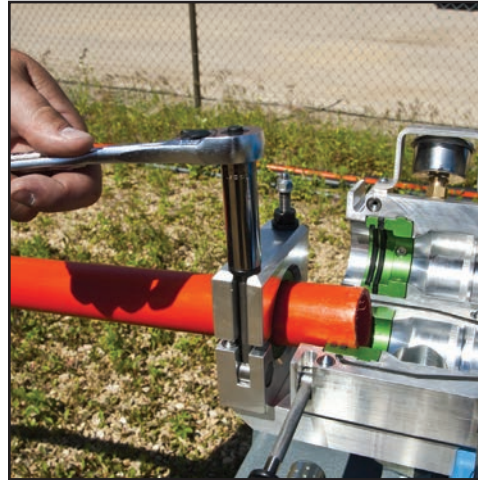

Figure 25. Clamp Conduit in Place

8. Place Seal Disk in Venturi slot. (Figure 26).
9. Close Air Block Cover and secure (Figure 27). Tighten nuts securely, but do not over tighten. Use a cross-tightening procedure.

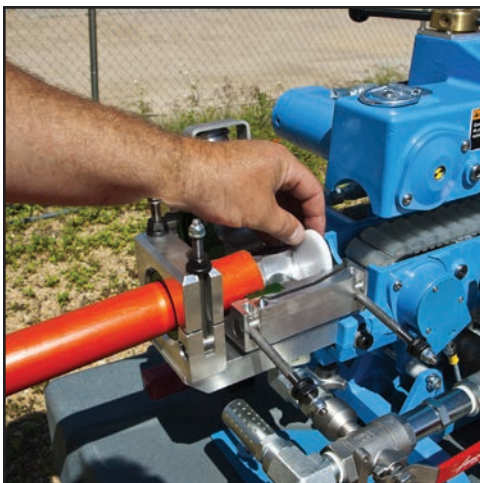

Figure 26. Installing Seal Disk

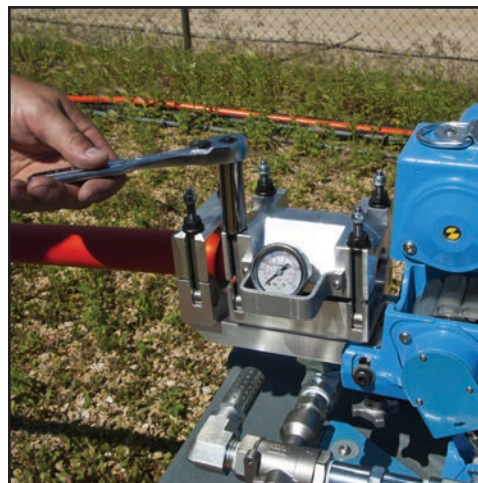

Figure 27. Tighten Air Block Cover

10. Plug receiving end of Conduit with a properly sized Conduit Pulling Eye (Figure 28) (Appendix R pg. 62).

11. Choose the correct Pulling Grip & install on receiving end of Conduit (Figure 29).



Figure 28. Installing Conduit Pulling Eye



Figure 29. Installing Pulling Grip

12. Connect the Air Compressor (Figure 30).

a. Ensure Air Valve is off before connecting air hose.

b. Attach the hose supplied with the air compressor to the air compressor coupling. The blower air valve assembly is equipped with a claw type connector. Use safety clips on all pneumatic hose connections (Figure 31).

c. Observe all safety procedures.

d. Route all hoses properly to prevent tripping over them.



!WARNING: Forced air creates flying debris. Always wear personal protective equipment. Severe personal injury could result.

!WARNING: Ensure no personnel are in the destination access vault during the blowing operation. Severe personal injury could result.

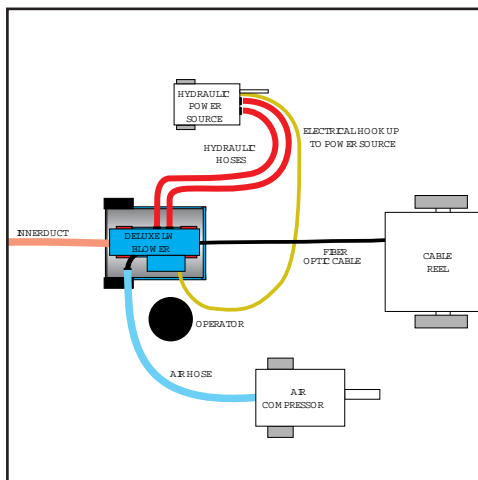

Figure 30. Typical Connections

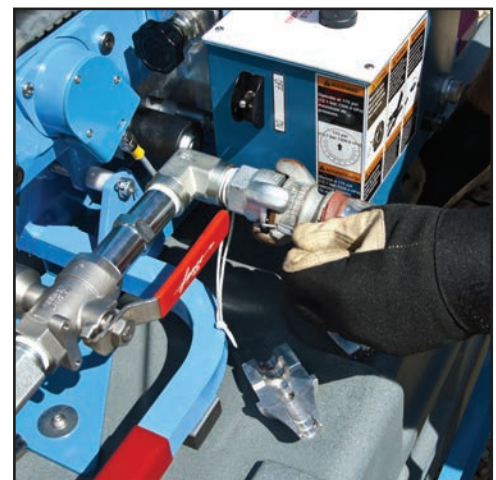

Figure 31. Installing Air Hose with Safety Clips

13. Slowly open Air Control Valve. Pressurize conduit to 80-100 psi (5.5-6.9 bar) (Figure 32).

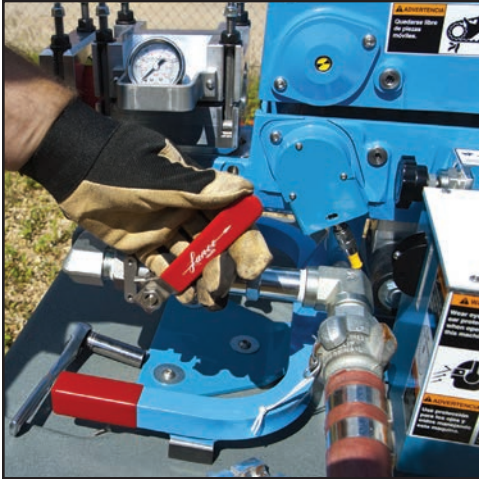

Figure 32. Open Air Control Valve



Figure 33. Close Air Control Valve

14. Prove conduit integrity.

a. Close Air Control Valve (Figure 33).

b. Conduit must not lose more than 20 psi (1.38 bar) over a 2-minute period.

c. After 2 minutes, relieve air pressure. Open air pressure relief valve by moving the blower pressure valve handle counter clockwise to the 9 o'clock position (Figure 34).

d. If conduit fails to hold required pressure, check entire conduit run for leaks and repair them.

e. Repeat the pressure test until all leaks are found and repaired.

!WARNING: Air Block Assembly contains compressed air when blower is operated. Opening Air Block while under pressure may cause serious personal injury. Ensure blower is depressurized before removing Air Block cover, or removing conduit pulling eye.



15. Decompress the Air Block by turning the Air Valve to the 9 o'clock position. Shut off the air at the compressor, decompress the air hose and disconnect the air hose from the fiber blower.



Figure 34. Decompress Air Block

Prepare Conduit for Cable

8.

1. Remove Conduit Pulling Eye and Pulling Grip from receiving end of Conduit. After removing pulling eye, re-install pulling grip in order to catch Foam Carrier during conduit lubrication (Figure 35).
2. Open the Air Block Cover (Figure 36).



Figure 35. Install Pulling Grip on Conduit

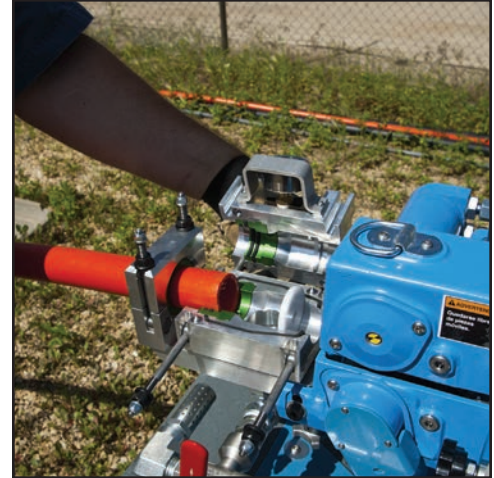

Figure 36. Open Air Block Cover

3. Tilt Blower forward (Figure 37).
4. Pour recommended (silicon-based) lubricant into Conduit opening before Foam Carrier: 1 quart/6000 feet (1 liter/2 km) (Figure 38) (See Appendix T for lubricant ordering information).

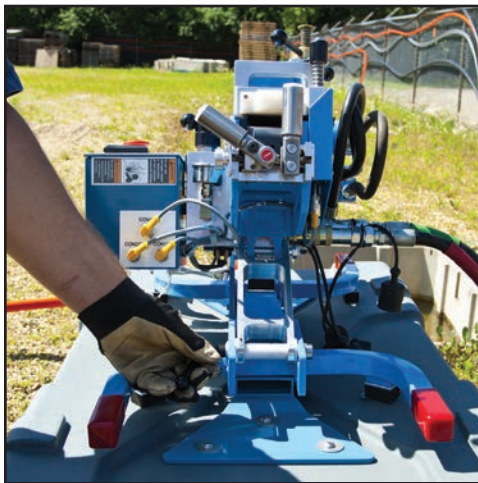

Figure 37. Loosen Handle to Tilt Blower



Figure 38. Pour Lube into Conduit

5. Insert Foam Carrier (selected according to conduit size) into Conduit (Figure 39) (See Table 2 on page 18).
6. Insert Seal Disk in venturi slot if not already in place. (Figure 40).



Figure 39. Insert Foam Carrier



Figure 40. Insert Seal Disk

7. Close the Air Block Cover. Tighten spanner nuts securely, but do not over tighten (Figure 41). Use cross tightening procedure with the ratchet to secure completely.

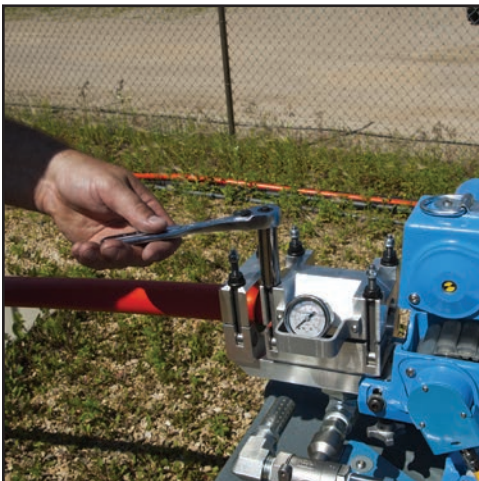

Figure 41. Tighten Air Block Cover

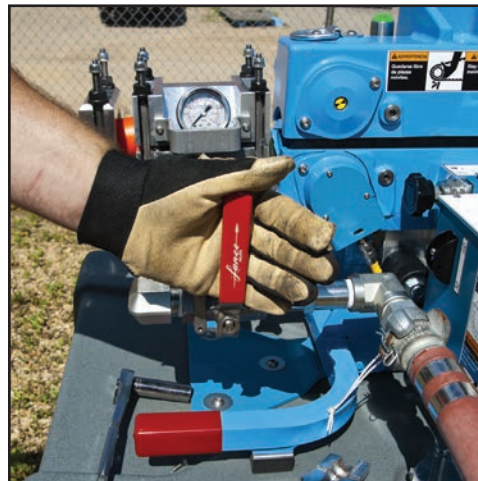

Figure 42. Close Air Control Valve

8. Prove conduit integrity and spread lubricant through Conduit.

- a. Re-connect the air hose to the fiber blower and attach all safety clips.
- b. Turn the Air Control Valve handle to the 12 o'clock position and turn on the air from the compressor (Figure 42).
- c. Slowly open Air Control Valve by turning to the 3 o'clock position.
- d. Blow Foam Carrier through conduit to spread lubricant and check for blockage. Follow all safety precautions.
- e. After the Foam Carrier exits, close Air Control Valve.

NOTE: Foam Carrier must exit in a reasonable time, allow for approximately 10 seconds per 1,000 feet (300 m) or conduit may be contaminated or blocked.

9. Ensure Air Block is depressurized. Open air pressure relief valve by moving the blower pressure valve handle counter clockwise to the 9 o'clock position (Figure 43). Shut off the air from the compressor, depress the air in the hose and disconnect the hose from the blower.

10. Remove Seal Disk and install Venturi (Figure 44).

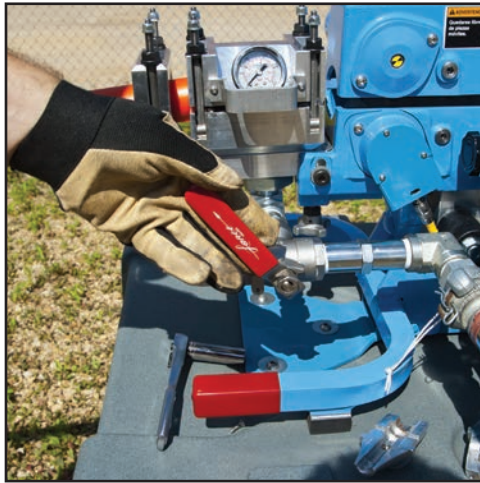

Figure 43. Decompress Air Block



Figure 44. Install Venturi

NOTE: The venturi with the groove goes into the bottom and gets screwed into place while the top half has the protrusions and sets into the groove (Figure 45).

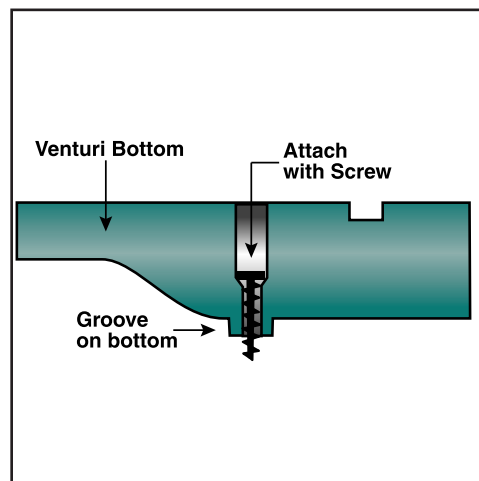

Figure 45. Install Venturi Bottom and Attach with Screw

Prepare Cable

The Deluxe Blower is designed so cable may be installed from the side. Follow these steps so cable is properly positioned to begin operation.

9.

1. Choose the correct Cable Grip and install on fiber optic cable (Figure 46)
(See Tables 1 & 2, on page 18).
2. Install 5/8" (16 mm) Swivel on Cable Grip. Grip must be firmly secured to cable (Figure 47). The eye on the grip can be compressed to fit smaller diameter conduits. The eye of a new grip can be taped with electrical tape in order to make it narrower and travel more easily through the conduit.



Figure 46. Install Cable Grip on Fiber Optic Cable



Figure 47. Install Swivel on Cable Grip

3. Choose the correct Carrier and install on Swivel (Figure 48).
4. Raise upper Tractor Drive Cover with turn crank (Figure 49). Open the rear cable guide roller by pulling out spring plunger and rotating the roller out (Figure 50).



Figure 48. Install Carrier



Figure 49. Raise Tractor Drive with Turn Crank

5. Tilt Blower forward (Figure 51).



Figure 50. Open Rollers

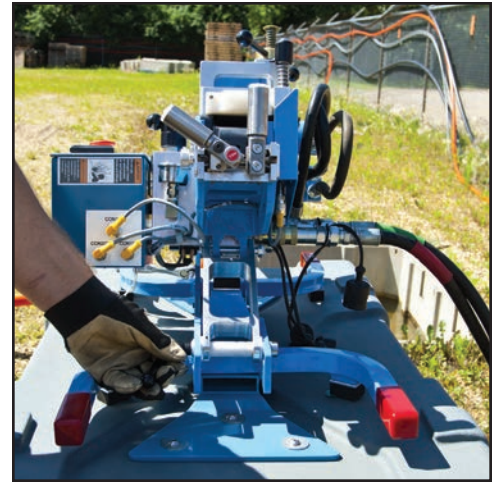

Figure 51. Tilt Blower

6. Add lubricant to Conduit before Carrier: 1/2 quart/6000 feet (.5 liter/2 km) (Figure 52).
7. Feed Cable Assembly through the counter rollers by lifting the Counter Roller Bracket. Lock the Rear Cable Guide Roller into place, and feed the cable through the Tractor Feed. (Figure 53).



Figure 52. Add Lubricant before Cable Assembly

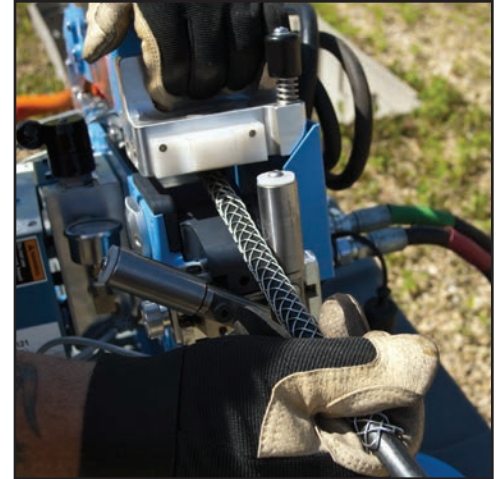

Figure 53. Feed Cable Assembly Through Blower

8. Push Cable Assembly, including entire Cable Grip, into Conduit.



Figure 54. Add Lubricant Behind Cable Assembly

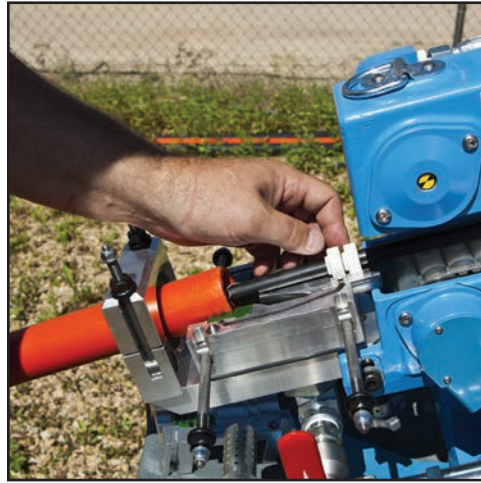

Figure 55. Install Cable Seals

9. Add lubricant to Conduit behind Cable Assembly: 1/2 quart/3000 feet (.5 liter/1 km) (Figure 54).

10. Choose the correct Cable Seals and install on cable. Grooved side of Cable Seal faces conduit. Place Cable Seals into Venturi, split side down (Figure 55).

11. Close Air Block Cover (Figure 56). Tighten nuts securely, but do not over tighten. Use cross tightening procedure to completely secure.

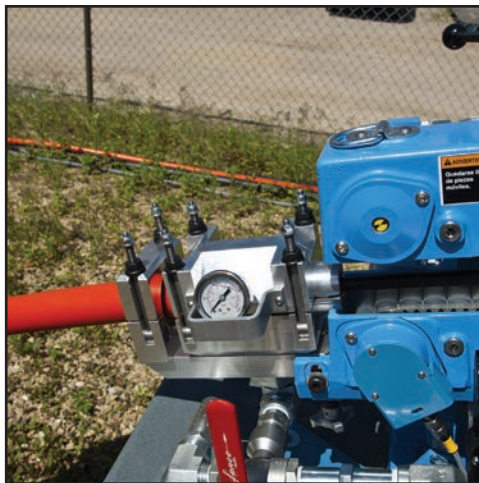

Figure 56. Close Air Block Cover

Final Set-Up

10.

1. Lower Tractor Drive Cover with turn crank until the cover reaches the stopper-bushing. The stopper-bushing will prevent the tractor cover from being clamped too tightly on the cable (Figure 57).
2. Level the height of Air Block's Venturi Tube with Tractor Drive and the approximate center line of the cable (Figure 58). Tighten slide cap screws after adjustments are made.
3. Notify crew that preparations are complete and cable blowing is to begin.
IMPORTANT: It is recommended that if a reel-tensioning unit is not being used, the cable reel should then be kept under control by a second operator who is required to wear proper safety equipment and maintain a proper distance from the cable.

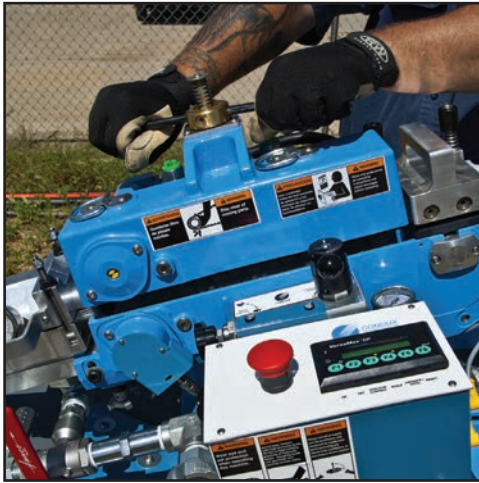

Figure 57. Lower Tractor Drive Cover With Turn Crank

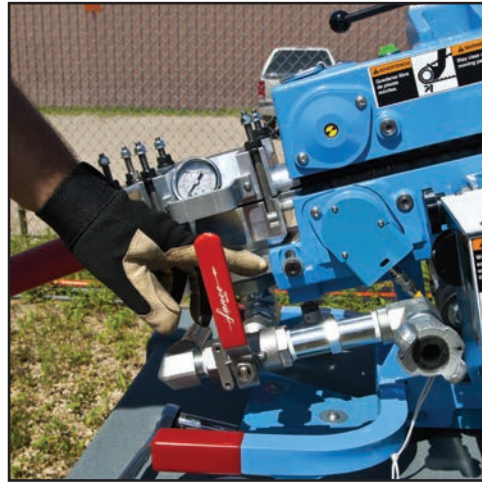

Figure 58. Level Air Block With Tractor Drive

A.

FINAL INSPECTION

!CAUTION: Before placing the blower into operation, always perform a final inspection of all components used.

1. Check that the Cable Grip is attached to conduit on receiving end.
2. Notify crew that preparations are complete and cable blowing is to begin.

Blower Operating Instructions

11.

A. OBSERVER AT EXIT PIT

Station an observer with a 2-way communication device, at the far end of the Conduit, where the Cable carrier will exit.

B. CONNECT THE HYDRAULIC SYSTEMS (Figure 59)

The Deluxe Blower's hydraulic system uses quick-disconnect couplings. Keep all connections clean to avoid contamination and possible system failure. Use hose end caps (supplied). A contaminated hydraulic system will effect the operation of the cable blower and may invalidate your product warranty. Take caution in routing the hoses to prevent a tripping hazard. Follow these steps to connect the hydraulic components:

1. Attach the quick-disconnect couplings to the hydraulic power supply (Figure 60).
2. Start the hydraulic power unit and check all connections for leaks with a piece of cardboard. In cold weather, run hydraulic power supply until hydraulic oil warms up.

WARNING: Escaping fluids under pressure can penetrate the skin and cause serious personal injury. Observe the following precautions to avoid hydraulic hazards:

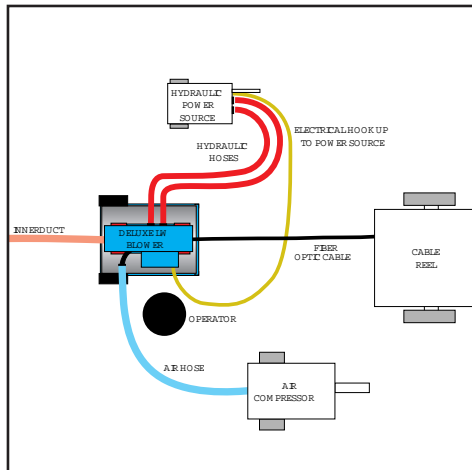

Figure 59. Typical Set-Up



Figure 60. Attach Hydraulic Hoses



Tighten all connections before applying pressure. Relieve pressure before connecting or disconnecting hoses.

- Check for leaks with a piece of cardboard. Do not use hands!
 - Do not exceed working pressure of hydraulic hoses. Visually inspect hoses regularly and replace if damaged.
3. Run the blower for approximately 1 minute to remove any trapped air and then stop the blower and hydraulic power source.

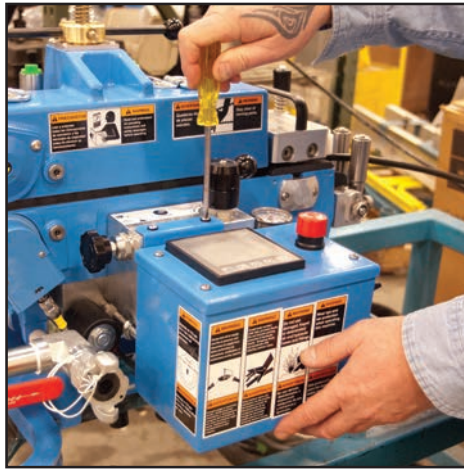

Figure 61. Install Electronic Control Box



Figure 62. Attach Power Cord

C. SET UP THE ELECTRONIC CONTROL BOX

1. Install Electronic Control Box on blower and secure with 1/4 turn fasteners (Figure 61).
2. Attach Power Cord and plug into 12 volt power supply (Figure 62). Take caution in routing the electrical cord to prevent a tripping hazard.
3. Attach solenoid valve, front tractor sensor, rear counter sensor, and transducer plugs (Figure 63).
4. Turn on control box power (Figure 64). Select the Traction Control required. Press the Traction Control button ON to activate. This stops the blower's tractor drive if the slippage or speed parameters are exceeded. Press OFF to disable this function.



Figure 63. Attach Sensor Plugs

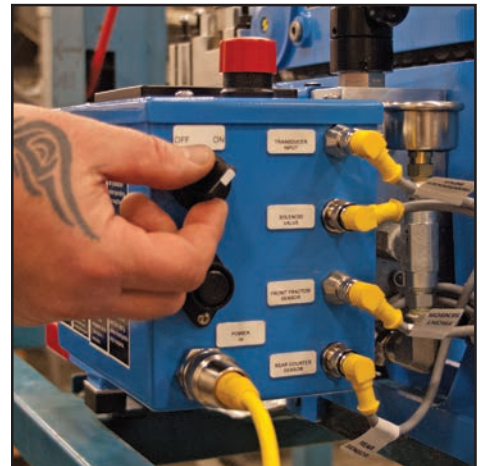

Figure 64. Turn on Control Box Power

D. PANEL LAYOUT

The Deluxe Blower Electronic Control Box uses a touch screen controller with four function buttons.

DRIVE:

OFF/F1: Disengages Hydraulics from the Blower. The OFF touch screen button will be highlighted when the unit is stopped. The operator can use either the touch screen button of the Function button.

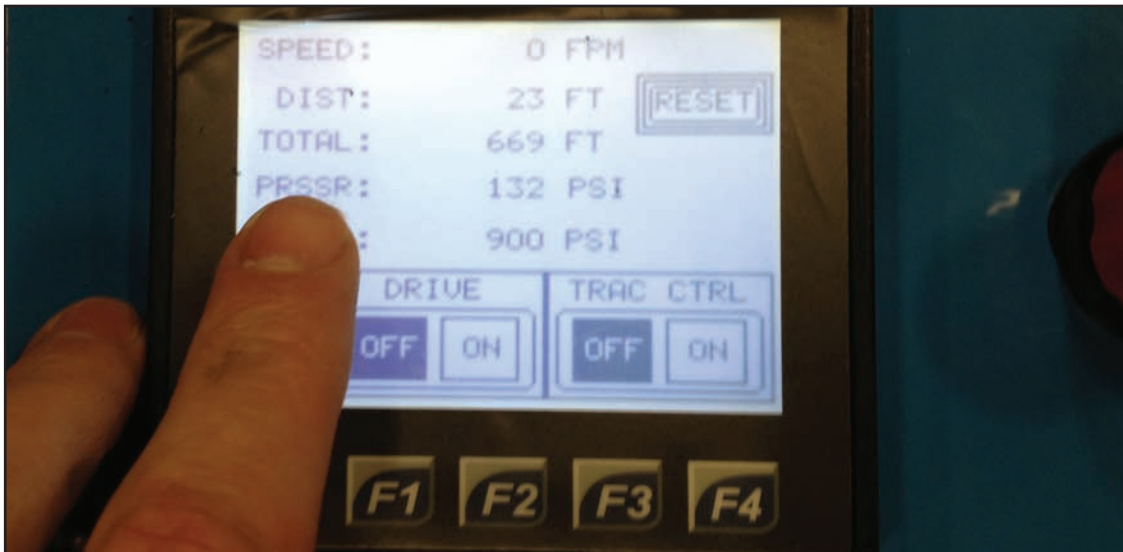

ON/F2: Engages Hydraulics to the Blower. The ON touch screen button will be highlighted when the unit is running. The operator can use either the touch screen button or the Function button.

CAUTION! Make sure the Hydraulic Flow Control Knob is turned all the way in before switching electronics to ON. Failure to do so could damage the cable.

TRACTION CONTROL (TRAC CTRL):

OFF/F3: Turns Traction Control feature OFF. The OFF touch screen button will be highlighted when the Traction Control feature is turned OFF. The operator can use either the touch screen button or the Function button.

ON/F4: Turns Traction Control feature ON. The ON touch screen button will be highlighted when the Traction Control feature is turned ON. The operator can use either the touch screen button or the Function button.

SCALE: Touching the touch screen on any of the Units (FPM/MPM, FT/M, PSI/BAR) will open a UNITS screen. Select from Metric or Imperial units, and press ENTER.

SPEED: Displays cable speed in Feet/Min or Meters/Min

DIST: Displays distance of current installation in Feet or Meters – Resettable

RESET: Touch Screen button that will reset DIST to 0

TOTAL: Displays lifetime distance on the machine in Feet or Meters – Non Resettable.

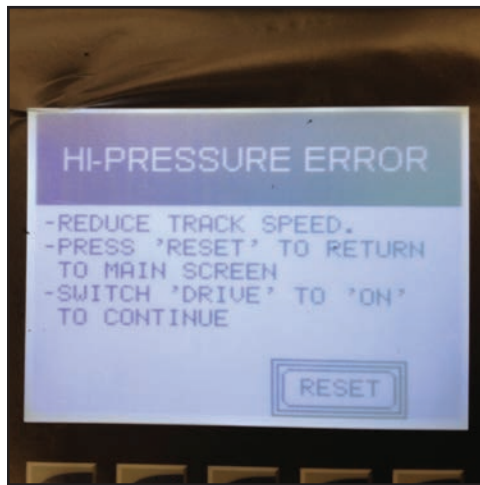

Figure 66. Hi-Pressure Error

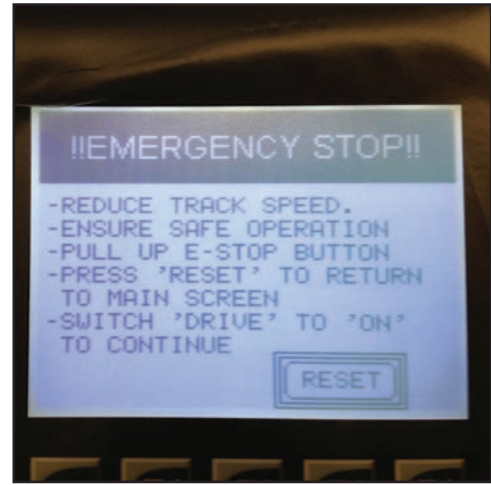

Figure 66A. Emergency Stop

PRSSR: Displays hydraulic working pressure in PSI or BAR. This pressure should match the pressure shown on the analog pressure gauge.

LIMIT: Displays the pressure limit set point in PSI or BAR. When the PRSSR value exceeds this set limit, the tractor drive will be stopped. This feature is NOT dependent on having the TRACTION CONTROL system turned ON. To change the LIMIT value, touch the screen in the LIMIT: XXXX area, and a keypad will appear. Enter the desired limit value and press ENTER to save the new value. Press ESC to exit screen without saving the new value.

When the pressure LIMIT is exceeded, the display will show:

HI-PRESSURE ERROR – follow on-screen instructions and press RESET at bottom of screen to return to operation (Figure 66).

EMERGENCY STOP BUTTON: Press the Emergency Stop button at any time to immediately stop

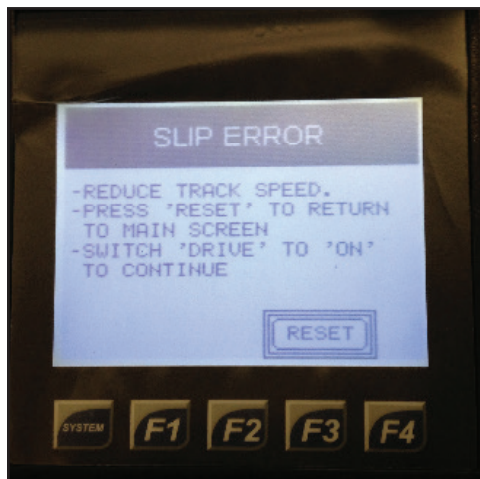

Figure 66B. Slip Error

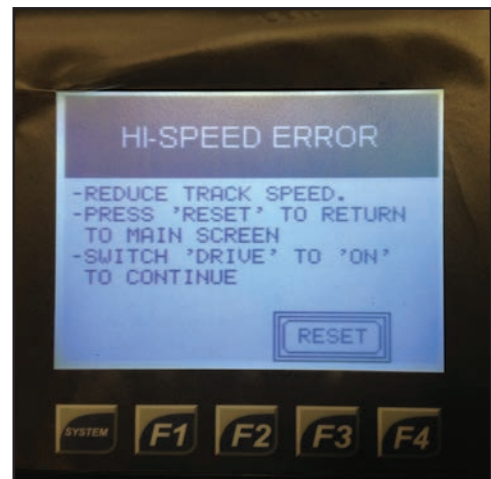

Figure 66C. Hi-Speed Error

the tractor drive. When the Emergency Stop button is pressed, the display will show:

!!EMERGENCY STOP!! – follow on-screen instructions and press RESET at bottom of screen to return to operation. The EMERGENCY STOP screen will not clear until the Emergency Stop button is pulled up (Figure 66A).



Figure 67. Turn on Hydraulics

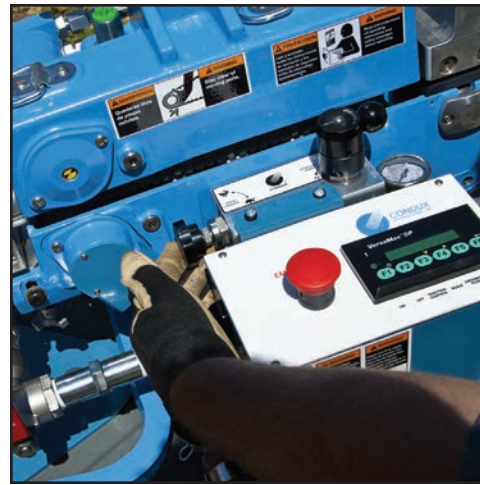

Figure 68. Rotate Hydraulic Flow Control Knob

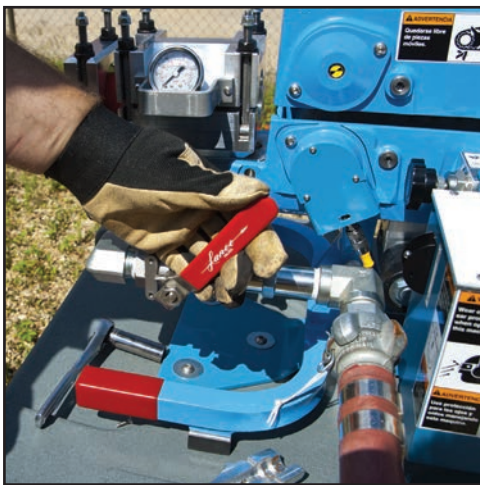

Figure 69. Turn On Air



Figure 70. Turn Off Air at the Air Block

E. TRACTION CONTROL

Once activated, the traction control will stop the blower's tractor drive if track speed goes above the maximum speed setting of 300 ft/min. (91 m/min.), or if the slippage allowance is exceeded. Slippage is measured by comparing the speed of the tracks with the speed of the cable being installed.

If slippage or speed parameters are exceeded, the display will show one of the following screens:

SLIP ERROR – follow on-screen instructions and press RESET at bottom of screen to return to operation (Figure 66B).

HI-SPEED ERROR – follow on-screen instructions and press RESET at bottom of screen to return to operation (Figure 66C).

DRIVE will be in OFF position after RESET. Press ON/F2 to resume cable installation.

F. OPERATION

1. Re-connect hose from air compressor and attach all safety clips. Start the Air





Compressor and Hydraulic Power Supply. Refer to respective manufacturers operating instructions for these units.

2. Make sure Electronics DRIVE is switched to ON. ON will be highlighted. Introduce a small amount of air to the system in order to straighten out the cable carrier inside the conduit. Turn the hydraulics to the “on” position (Figure 67). Slowly rotate the flow control knob, counterclockwise to engage tractor drive and increase speed (Figure 68). Push cable 50 to 100 feet (15 to 30 m) into Conduit.
3. Slowly open the Air Control Valve to allow air flow to the Air Block by turning flow control handle clockwise to the 3 o’clock position so it is in line with the air compressor hose (Figure 69).
4. Maintain control of cable reel to ensure smooth, stable flow. Failure to do so may cause cable to unwind too quickly. Continue to control cable speed with the flow control knob.

!WARNING: Never wrap line around your hand, arm, foot, or leg. Severe personal injury or death could result from entanglement.

!CAUTION: Always wear protective equipment: hard hat, safety glasses,



Figure 71. Turn Off Air at the Air Block



Figure 72. Decompress Air Block

safety shoes and work gloves.

5. Turn Tractor Drive off immediately when the observer indicates the Cable Carrier has exited the Conduit (air pressure will decrease sharply).

- The Tractor Drive will continue to travel unless the track speed exceeds the slippage allowance, or the maximum speed of 300 ft/min. (91 m/min.) is exceeded for more than 2 seconds. The OFF/F1 button will also stop the tractor drive.

- Press start to allow Tractor Drive to resume.



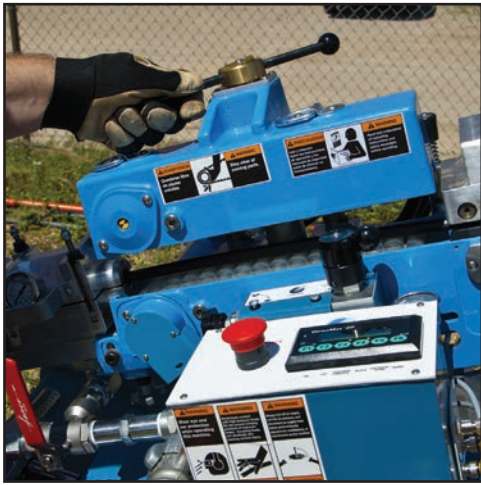
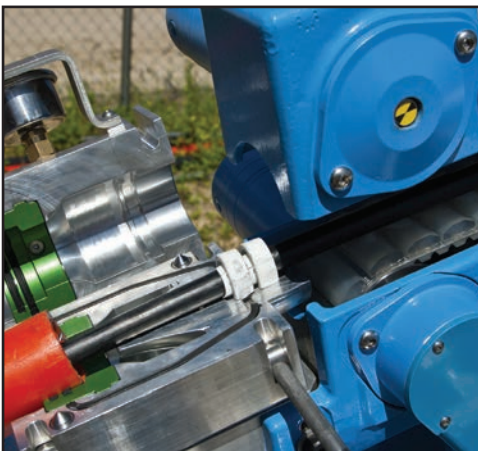

Figure 73. Raise Tractor Drive Cover



Figure 74. Turn Off Hydraulic Power



NOTE: If the TRACTION CONTROL (TRAC CTRL) is set to OFF, the Tractor Drive will continue to operate regardless of the slippage and speed parameters.

6. Turn off compressed air flow to the Air Block (Figure 70).
!WARNING: Air Block Assembly contains compressed air when blower is operated. Opening Air Block while under pressure may cause serious personal injury. Ensure blower is depressurized before removing Air Block cover.
7. Remove Cable Grip from receiving end of Conduit.
8. If electronics stop blower before Cable Carrier exits, restart blower, making sure speed is within minimum and maximum allowance. Also see Troubleshooting Guide.

Tear Down Procedures

!WARNING: Air Block Assembly contains compressed air when blower is operated. Opening Air Block while under pressure may cause serious personal injury. Ensure blower is depressurized before removing Air Block cover.

A. REMOVE POWER FROM UNIT.

1. Turn off compressed air by closing the Air Control Valve at the blower (Figure 71). Shut off air at the compressor and decompress air hose. Depressurize the air block by turning the air control valve to the 9 o'clock position (Figure 72). Remove air hose when system is relieved of pressure.
2. Raise Tractor Drive Cover with turn crank (Figure 73).
3. Turn off Hydraulic Power Supply and disconnect hydraulic hoses (Figure 74). Keep all connections free of dirt and particles. Use hose end caps (supplied).
4. Disconnect electronic cords.

!WARNING: Escaping fluids under pressure can penetrate the skin and

cause serious personal injury. Release pressure before disconnecting hoses.

13.

Procedure	Daily	Weekly	Monthly	60 Days	90 Days
Clean all assemblies and components thoroughly.	X	X	X	X	X
Inspect hoses for cracks and leaks.	X	X	X	X	X
Inspect fasteners and screws.	X	X	X	X	X
Check Belt Tension. Replace if excess wear has occurred.	X	X	X	X	X
Grease rear top shell alignment posts using available grease zerks.			X		
Lubricate Tractor adjustment bolt with grease zerks located on adjustment handle.				X	
Oil Oilite bearings on the counter clamp with light machine oil.					X

Figure 77. Maintenance Schedule

B. REMOVE CABLE FROM BLOWER.

1. Open Air Block Cover and remove Cable Seals (Figure 75).
2. Pull the Guide Roller Knob and move Rear Guide Roller into open position. Lift Counter Roller Knobs so rollers are clear of cable (Figure 76). Pull cable out from side of unit.

C. SEPARATE UNIT FROM CONDUIT.

1. Open Conduit Clamp.
2. Pull unit away from Conduit.
3. If repositioning the machine, the Deluxe Blower should not be parked on a slope in excess of 13°. It should not be parked on a side hill of more that 15°.

Maintenance

CAUTION: Operators are not permitted to perform maintenance tasks unless Condux personnel or representatives have appropriately trained them. Disconnect the machine from its electrical, pneumatic, and hydraulic power sources before servicing.

A. TRACK CLEANING AND TIGHTENING

1. Inspect track before and after each use.
2. Clean after each use, or when necessary. Remove the top assembly to clean thoroughly by:
 - Remove top capscrew with a 3 mm allen wrench and the flat washer on clamp adjustment screw. This will allow for the top track assembly to be unscrewed off the blower with the clamp adjustment (Reference Appendix K).

- Pressure wash if necessary

3. To compensate for normal belt stretching, there is a rubber dampening bushing part number 08780028, which is lobed larger on one side than the other, located at the pivot position of the idler skid part number 08780105. It is in the smaller lobe position when it leaves the factory. If a tighter belt is needed, rotate the bushing so the skid presses against the larger lobe. Be sure to have both bushings in the same configuration before locking the skid back into position. If this is not enough, then new tracks must be purchased (Reference Appendix B & C).

B. REPLACEMENT OF THE DRIVE BELT

The drive belt needs to be replaced when the machine is unable to tractor drive the specified range of cable diameters. Only genuine spares should be used otherwise the machine may be unsafe and void warranty (Reference Appendix B & C).

	Metric Thread Size	Class 4.6		Class 8.8		Class 10.9		Class 12.9	
		Lubricated	Dry	Lubricated	Dry	Lubricated	Dry	Lubricated	Dry
in lbs	3	4.4	6.2	n/a	n/a	n/a	n/a	15	19
	3.5	8	9.7	n/a	n/a	n/a	n/a	23	31
	4	10.6	13.3	n/a	n/a	n/a	n/a	34	45
	5	16	21	41	55	59	78	69	91
	6	27	36	70	92	100	132	117	156
	7	45	60.5	117	156	167	223	195	260
	8	66	87.5	169	226	240	324	299	372
ft lbs	10	11	15	28	37	40	53	47	62
	12	19	25	49	65	70	92	81	108
	14	30	40	105	103	111	148	129	173
	16	47	62.5	125	167	173	231	202	269
	18	66	86	172	230	238	317	249	371
	20	91.5	122	243	325	338	450	395	526
	22	125	166	332	443	459	612	536	715
	24	158	210	420	562	583	778	682	909
	27	232	308	617	822	853	1,138	997	1,330
	30	314	419	838	1,117	1,160	1,545	1,355	1,807
	33	428	570	1,140	1,520	1,577	2,103	1,844	2,458
	36	550	732	1,454	1,962	2,025	2,701	2,368	3,156

Figure 78. Torque Specifications for Steel into Steel

	Metric Thread Size	Class 4.6		Class 8.8		Class 10.9		Class 12.9	
		Lubricated	Dry	Lubricated	Dry	Lubricated	Dry	Lubricated	Dry
in lbs	3	2.64	3.72	n/a	n/a	n/a	n/a	9	11.4
	3.5	4.8	5.82	n/a	n/a	n/a	n/a	13.8	18.6
	4	6.36	7.98	n/a	n/a	n/a	n/a	20.4	27
	5	9.6	12.6	24.6	33	35.4	46.8	41.4	54.6
	6	16.2	21.6	42	55.8	60	79.8	70.2	93.6
	7	27	36.3	70.2	93.6	100.2	133.8	117	156
	8	39.6	52.5	101.4	135.6	144	194.4	172.8	223.2
ft lbs	10	6.6	9	16.8	22.2	24	31.8	28.2	37.2
	12	11.4	15	29.4	39	42	55.2	49.5	64.8
	14	18	24	63	61.8	66.6	88.8	77.4	103.8
	16	28.2	37.5	75	100.2	103.8	138.6	121.2	161.4
	18	39	51.6	103.2	138	142.8	190.2	149.4	222.6
	20	54.9	73.2	145.8	195	202.8	270	237	315.6
	22	75	99.6	199.2	265.8	275.4	367.2	321.6	429
	24	94.8	126	252	337.2	349.8	466.8	409.2	545.4
	27	139.2	184.8	370.2	493.2	511.8	682.8	598.2	798
	30	189.4	251.4	502.8	670.2	696	927	813	1084.2
	33	256.8	342	684	912	946.2	1261.8	1106.4	1474.8
	36	330	439.2	878.4	1171.2	1215	1620.6	1420.8	1893.6

Figure 79. Torque Specifications for Steel Capscrew into Aluminum

Troubleshooting Guide

14.

Problem	Solution
Cable becomes jammed in the conduit system.	<ol style="list-style-type: none"> 1. Inform the people at the other end of the conduit that a problem has been experienced and the operator is going to shut down the system. 2. Shut off the hydraulic valve at the blower. 3. Shut off the pneumatic air supply with the Air Control Valve turning it to the 9 o'clock position, allowing the air pressure to be depressurized from the conduit and the air block. 3. Using the counter or the measurement on the cable, determine where the blockage might be located. 5. Notify supervisor about problem and determine a solution accordingly.
Tractor Feed does not pull the cable off the reel.	Assist the reel by pushing it, and/or by pulling the cable off the reel.
Blower cuts out with electronic error or highspeed error.	Blower has exceeded the maximum speed allowance. Adjust speed accordingly, or wipe cable clean from mud and dirt.
It is difficult to keep the cable moving near the end of the conduit run.	Assist the blower by manually pushing the cable into the conduit. Do not bend or crimp the cable.
The cable run is hard to restart after having stopped.	Put air to the system with the track down. The tractor feed can be restarted after the air pressure has increased and stabilized.
Tractor feed doesn't start.	<ol style="list-style-type: none"> 1. Hydraulic flow control is at the lowest speed-increase flow speed slowly. 2. Hydraulic "on"/"off" is in the "off" position-rotate handle to the "on" position. 3. Electronics is in the "stop" position-push the "start" button. 4. "E-stop" is still in the active mode-rotate clockwise to allow the button to reset. 5. Hydraulic power pack is in the "off" position-turn it to the "on" position. 6. Check that the hydraulic hoses are connected correctly.

Blower with Job Box



APPENDIX

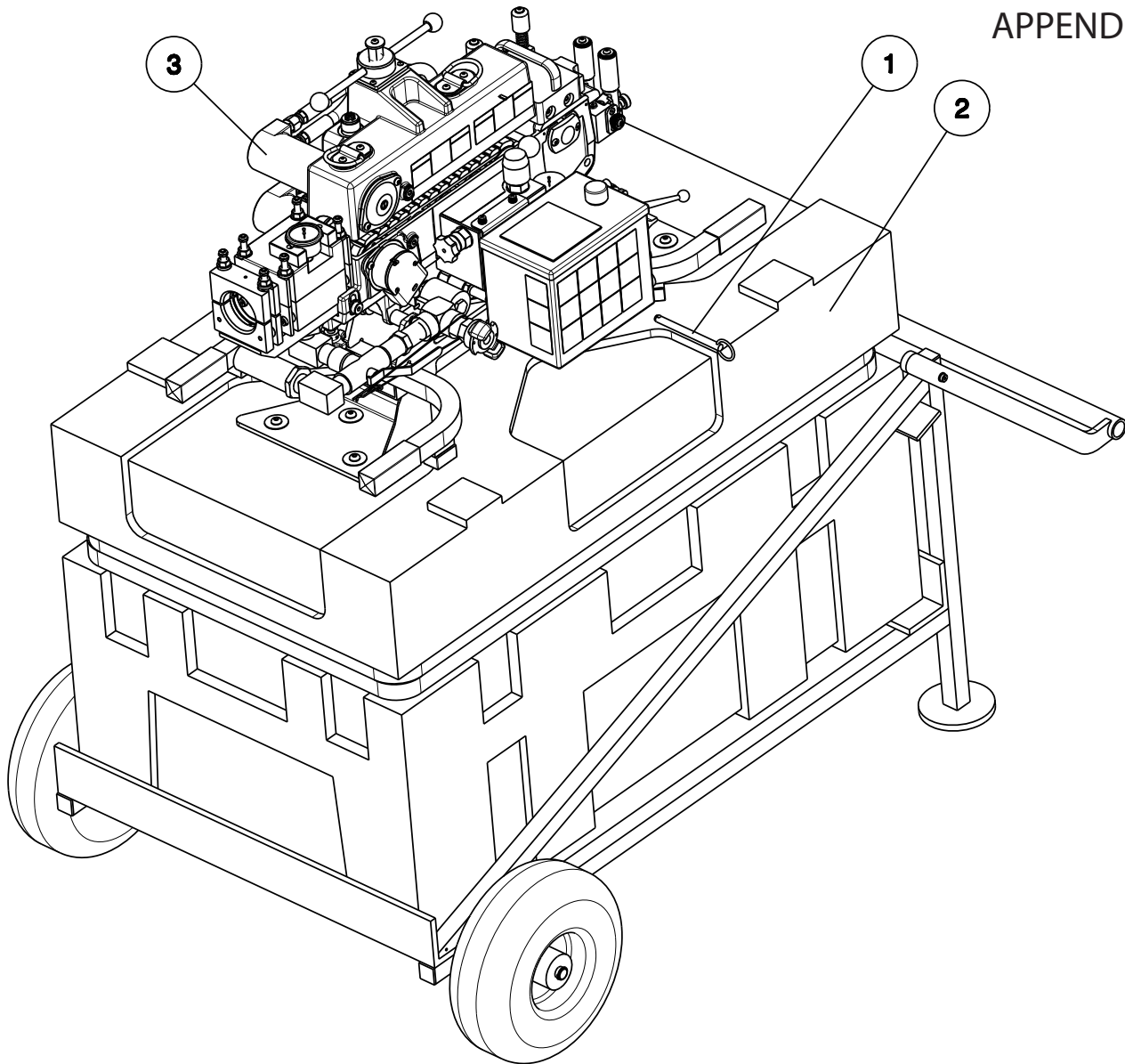

Blower with Job Box

ITEM	PART NO	DESCRIPTION	QTY
1	02288701	Pin, Hitch Cotterless 3/8 x 4.50	1
2	08780195	Cart, Job Box LW FO Blower-Assy	1
3	08782000	Blower, LW Fiber Optic-Deluxe	1
ITEMS 1, 2 ARE NOT INCLUDED WITH 08782000			

Parts List, Blower with Job Box

Upper Drive Shaft Kit

B.

APPENDIX

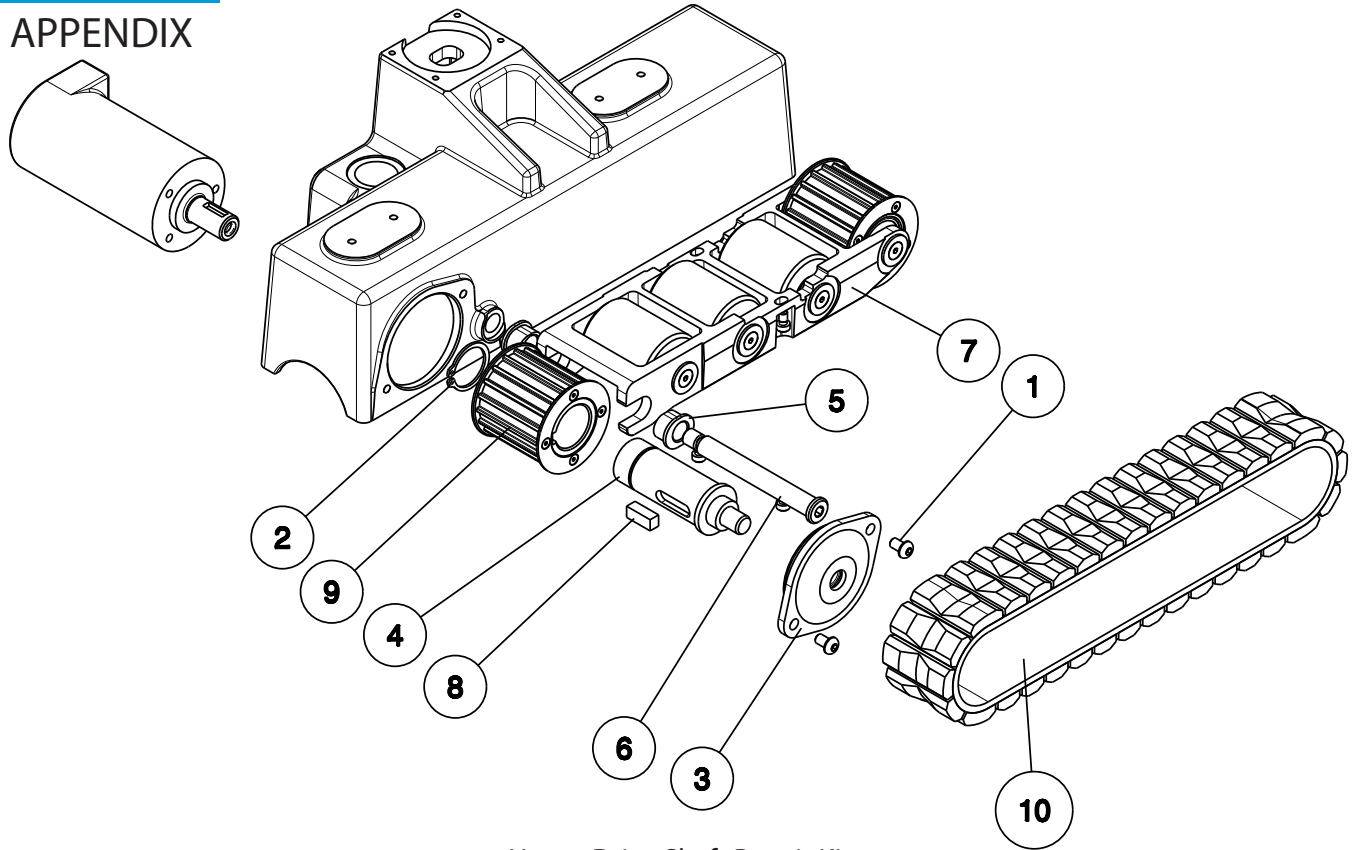

Upper Drive Shaft Repair Kit
08780625

ITEM	PART NO	DESCRIPTION	REQUIRED QTY	KIT QTY
1	02288583	Capsrw M06-1.0 X 10 BHSS 18-8	2	2
2	02288656	Ring, Retaining 28MM Ext (3100)	1	1
3	08780010	Cap, Bearing Assy-Upper Drvshft	1	1
4	08780011	Shaft, Upper Drive-Upr Drv Assy	1	1
5	08780642	Bushing, Dampening (Kit includes 2)	1	NA
6	08780029	Shaft, Pivot-Idler Assy	1	NA
7	08780105	Bracket, Idler Roller Mnt Assy	1	NA
8	08780181	Key, Drive Shaft 7mm-8mm-19.5mm	1	1
9	08780664	Pulley, Timing Drv-Assy	1	1
10	08780904	Belt, Cable 50mm x 260mm Center	1	NA
08780625 KIT INCLUDES ITEMS: 1, 2, 3, 4, 8 & 9				

Parts List, Upper Drive Shaft Repair Kit
08780625

Lower Drive Shaft Kit



APPENDIX

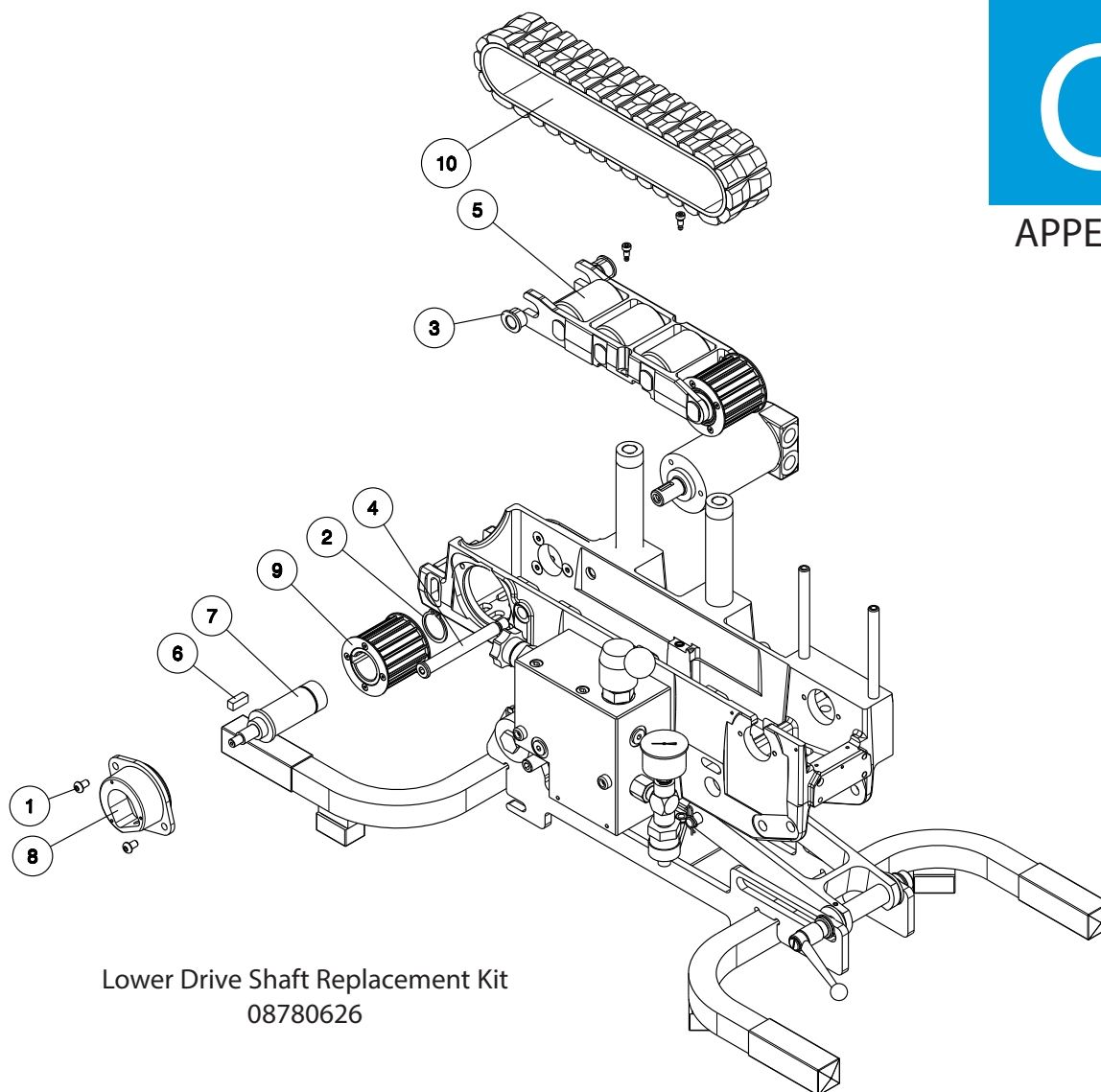

Lower Drive Shaft Replacement Kit
08780626

ITEM	PART NO	DESCRIPTION	REQUIRED QTY	KIT QTY
1	02288583	Capsrw M06-1.0 X 10 GHSS 18-8	2	2
2	02288656	Ring, Retaining 28MM Ext (3100)	1	1
3	08780642	Bushing, Dampening-(Kit includes 2)	1	NA
4	08780029	Shaft, Pivot-Idler Assy	1	NA
5	08780105	Bracket, Idler Roller Mnt Assy	1	NA
6	08780181	Key, Drive Shaft 7mm-8mm-19.5mm	1	1
7	08780277	Shaft, Lower Drive-Lwr Drv Assy	1	1
8	08780278	Cap, Bearing Assy-Lower Drvshft	1	1
9	08780664	Pulley, Timing Drv-Assy	1	1
10	08780904	Belt, Cable 50mm x 260mm Center	1	NA
08780626 KIT INCLUDES ITEMS: 1, 2, 6, 7, 8 & 9				

Parts List, Lower Drive Shaft Replacement Kit
08780626

Hydraulic Motor Kit

APPENDIX

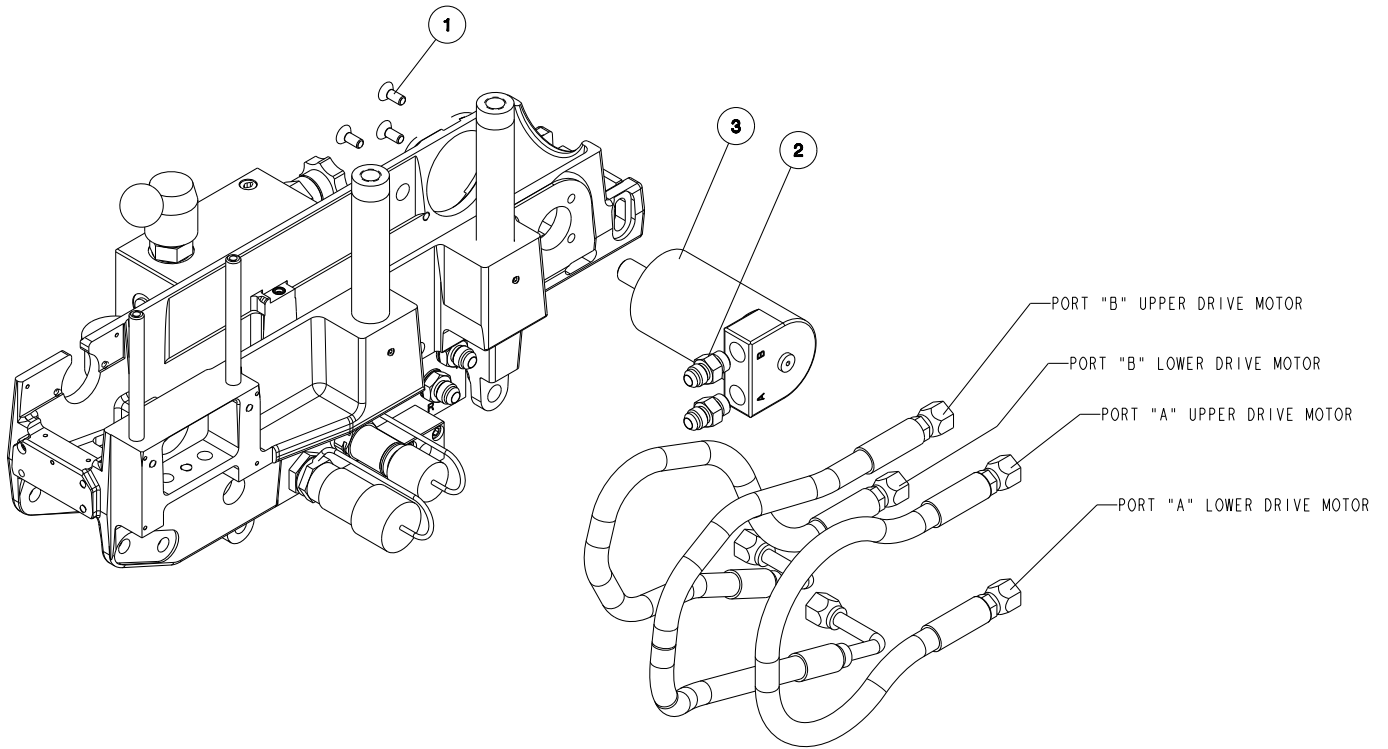

Hydraulic Motor Replacement Kit
08780636

ITEM	PART NO	DESCRIPTION	REQUIRED QTY	KIT QTY
1	02269664	CAPSRW 0.25-20X0.62 CSSTALY PL	3	3
2	02269694	FTG,HYD 06 O-RING;06-JIC	2	2
3	08780940	MOTOR,HYD 5/8 SHAFT-PAINTED	1	1

Parts List, Hydraulic Motor Replacement Kit
08780636

Idler Bracket Bushing & Screw Kits



APPENDIX

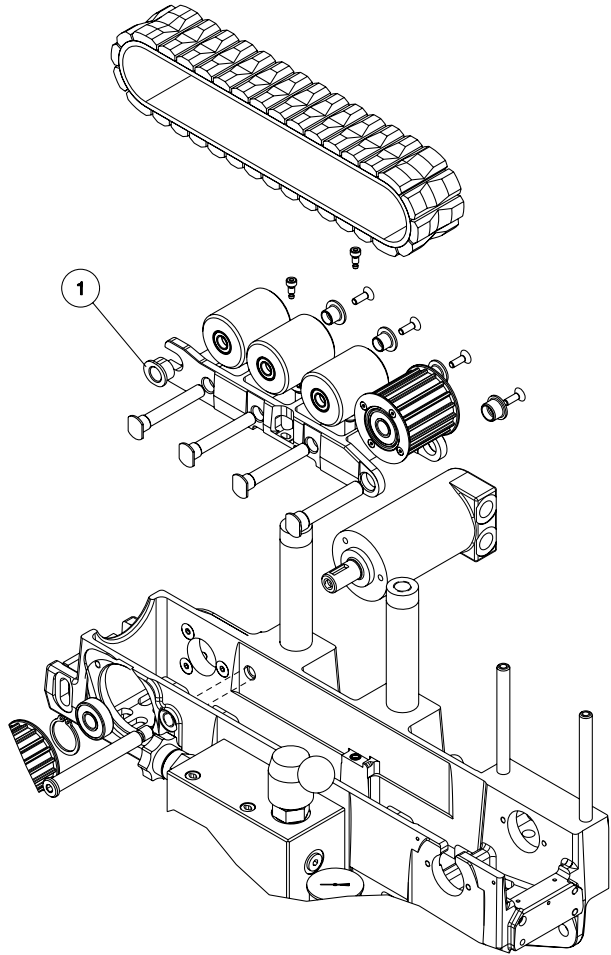

Idler Bracket Bushing Replacement Kit
08780642

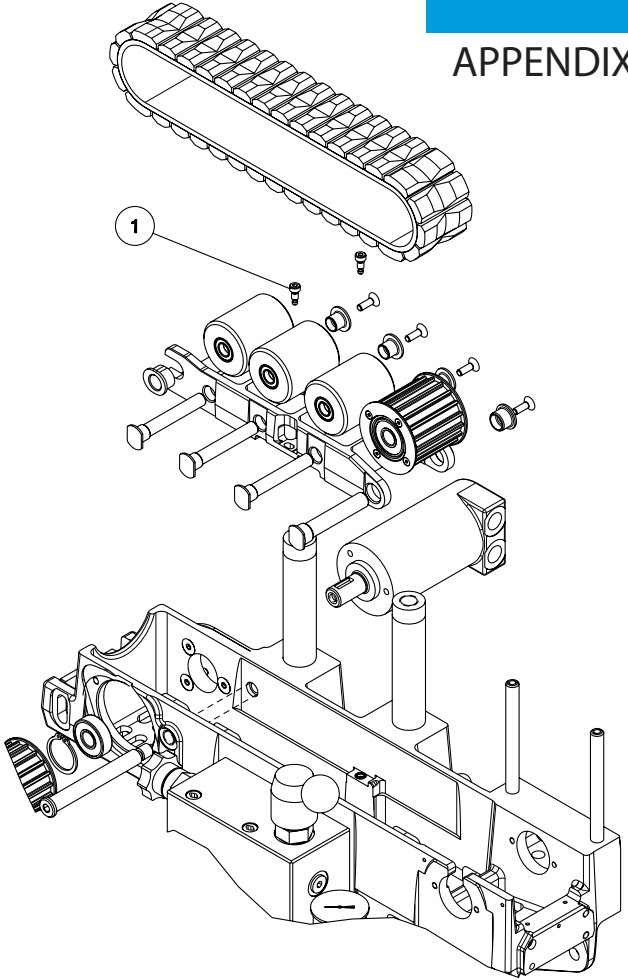

Idler Bracket Screw Replacement Kit
08780643

ITEM	PART NO	DESCRIPTION	REQUIRED QTY	KIT QTY
1	08780028	Bushing, Dampening-Polyurethane	2	2

Parts List, Idler Bracket Bushing Replacement Kit
08780642

ITEM	PART NO	DESCRIPTION	REQUIRED QTY	KIT QTY
1	02290189	Screw, Shoulder M05 Dia-8mm Lg	2	2

Parts List, Idler Bracket Screw Replacement Kit
08780643

Air Block Assembly Kits



APPENDIX

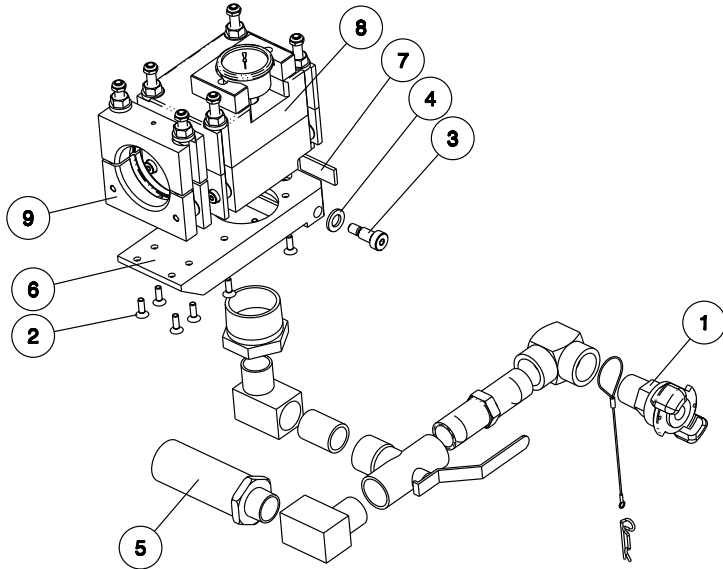

Airblock Bracket Replacement Kit
08780629

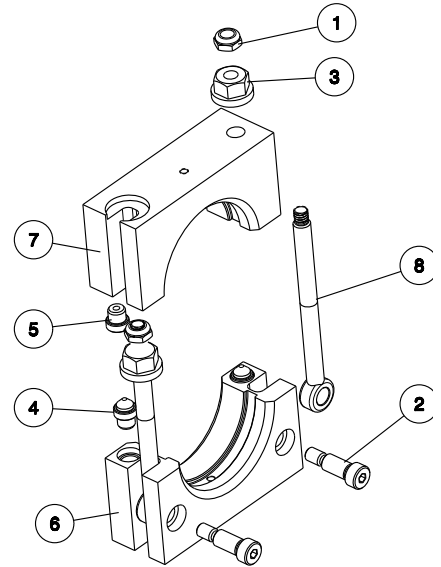

Airblock Clamp Assembly
Replacement Kit
08780942

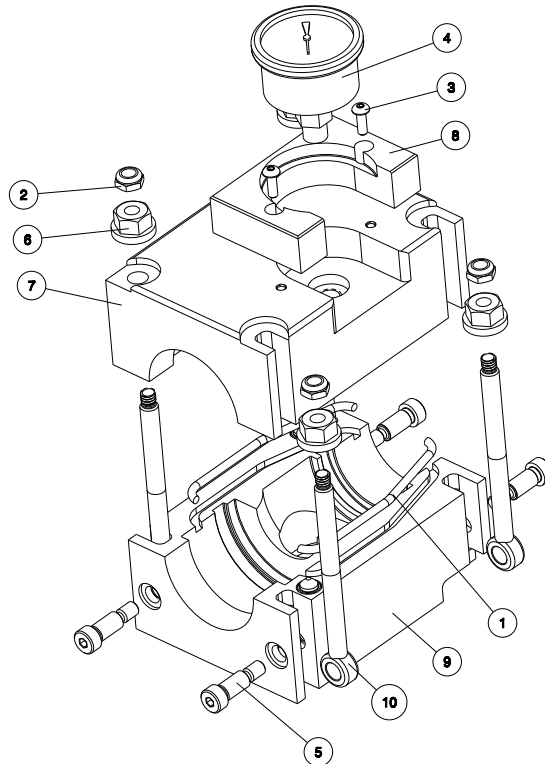

Airblock Assembly Replacement Kit
08780935

ITEM	PART NO	DESCRIPTION	REQUIRED QTY	KIT QTY
1	02129701	Coupling, Universal 3/4 Male	1	NA
2	02288573	Capsrw M05-0.8 X 16 CSSS 18-8	8	8
3	02288605	Screw, Shoulder M10 Dia-16mm Lg	2	2
4	02288606	Flatwasher M10-Narr St Cz	2	2
5	02288671	Muffler, Pneumatic Exhaust 12MP	1	NA
6	08780159	Mount, Airblock (W/Insert) LW FO Blwr	1	1
7	08780258	Pad, Guide-LW Airblock Mount	2	2
8	08780935	AIRBLOCK, LW BLOWER ASSEM - NEW	1	NA
9	08780942	BLOCK, CLAMP(ASSY) SWINGBOLT	1	NA
08780629 KIT INCLUDES ITEMS: 2, 3, 4, 6 & 7				

Parts List, Airblock Bracket Replacement Kit - 08780629

ITEM	PART NO	DESCRIPTION	REQUIRED QTY	KIT QTY
1	02288416	1/4-20 THIN NYLOC NUT (CLEAR ZINC)	2	1
2	02289401	5/16 DIA X 5/8 SHOULDER SCREW (1/4-20 THRDS)	2	1
3	02290167	5/16-18 SWIVEL FLANGE HEX NUT	2	1
4	NA	LOCATOR PIN	NA	NA
5	NA	LOCATOR BUSHING	NA	NA
6	NA	LOWER SWING BOLT CLAMP BODY	NA	NA
7	NA	UPPER SWING BOLT CLAMP BODY	NA	NA
8	08782314	SWING BOLT-MACHINED	4	1
	08782321	CLAMP BODY (INCLUDES 4, 5, 6 & 7)	1	NA
	08782322	SWING BOLT KIT(INCLUDES 1ea 1, 2, 3 & 8)	2	NA

Parts List, Airblock Clamp Assembly Replacement Kit - 08780942

ITEM	PART NO	DESCRIPTION	REQUIRED QTY	KIT QTY
1	08780126	QUAD-RING, 3.5MM-KIT	1	NA
2	02288416	NUT 0.25-20 NYLOC STGR2 THN CZ	4	1
3	02288571	CAPSRW M04-0.7X 12 BHSS 18-8	2	NA
4	02288582	GAUGE, PRESS 0- 200 1.50 BCK MT	1	NA
5	02289401	SCREW, SHOULDER 0.312 DIA-0.625	4	1
6	02290167	NUT 0.31-18 HEX SWIVEL FLANGE	4	1
7	08780937	AIRBLOCK, UPPER MACH - LW	1	NA
8	08780938	GUARD, GAUGE-MACH- LW FOB	1	NA
9	08780941	AIRBLOCK, LOWER MACH-SWINGBOLT	1	NA
10	08782314	BOLT, SWING-MODIFIED-DLX BLOWER	4	1
	08782322	SWING BOLT KIT (INCLUDES 1ea - 2, 5, 6 & 10)	4	NA

Parts List, Airblock Assembly Replacement Kit - 08780935

Counter Clamp Roller & Cable Guide Kits



APPENDIX

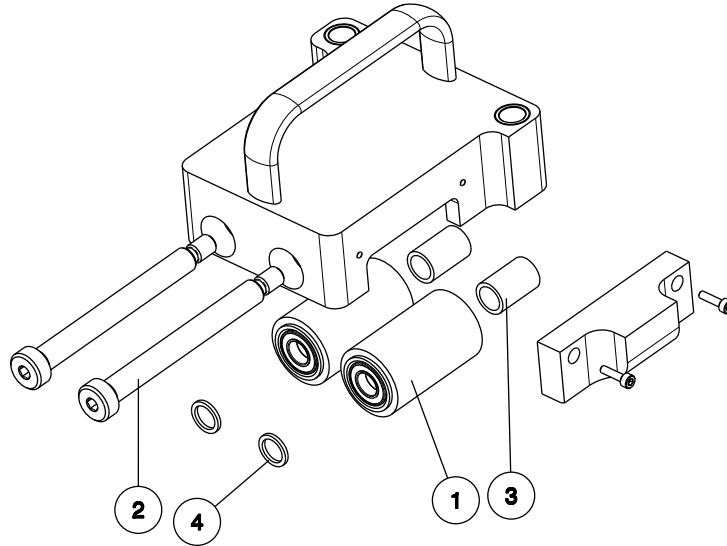

Counter Clamp Roller Replacement Kit
08780630

ITEM	PART NO	DESCRIPTION	REQUIRED QTY	KIT QTY
1	08780091	Roller, Cable Clamp-Assy	2	1
2	08780094	Shaft, Cable Clamp Roller	2	1
3	08780095	Spacer, 10mm-14mm-21.5mm Nylon	2	1
4	08780096	Spacer, 10mm-14mm-1.5mm Nylon	2	1

Parts List, Counter Clamp Roller Replacement Kit
08780630

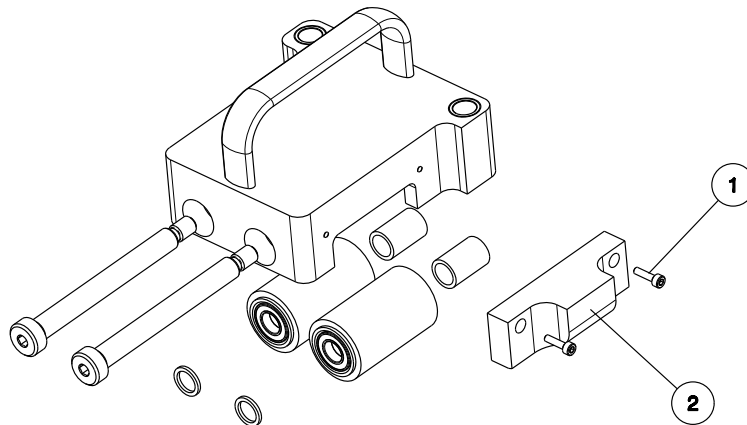

Counter Cable Guide Replacement Kit
08780631

ITEM	PART NO	DESCRIPTION	REQUIRED QTY	KIT QTY
1	02288649	Capsrw M03-0.5 X 12 SHAA 18-8	2	2
2	08780266	Guide, Cable-Upper Entrance	1	1

Parts List, Counter Cable Guide Replacement Kit
08780631

Timing & Takeup Roller & Idler Roller Kits



APPENDIX

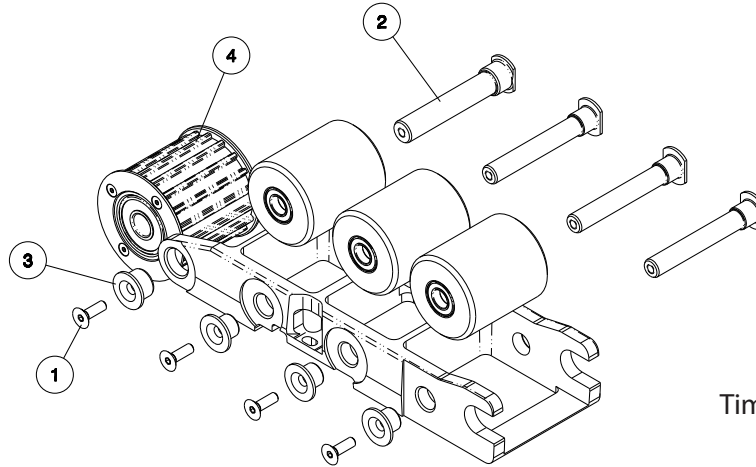

Timing & Takeup Roller Replacement Kit
08780632

ITEM	PART NO	DESCRIPTION	REQUIRED QTY	KIT QTY
1	02288573	Capsrw M05-0.8 X 16 CSSS 18-8	4	1
2	08780006	Shaft, Idler Pulley-BT Blower	4	1
3	08780037	Retainer, Idler Pllly-12mm Shaft	4	1
4	08780663	Pulley,Timing Idler-Assy	1	1

Parts List, Timing & Takeup Roller Replacement Kit
08780632

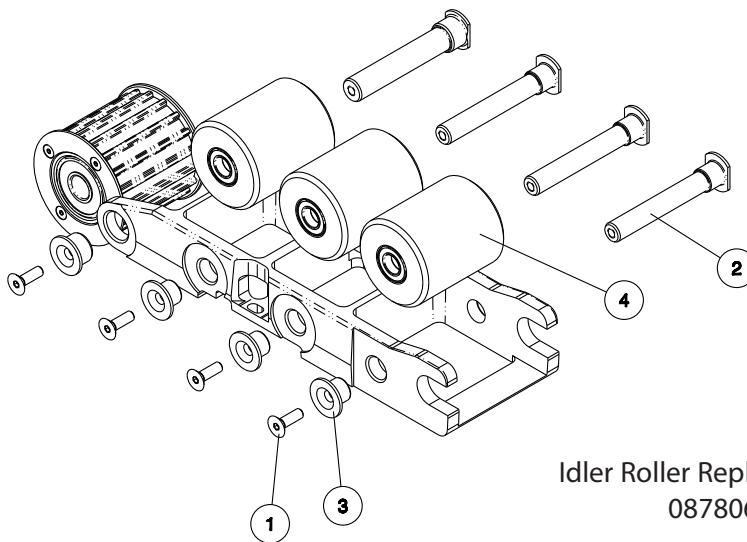

Idler Roller Replacement Kit
08780633

ITEM	PART NO	DESCRIPTION	REQUIRED QTY	KIT QTY
1	02288573	Capsrw M05-0.8 X 16 CSSS 18-8	3	1
2	08780007	Shaft, Idler Roller-LW Blower	3	1
3	08780031	Retainer, Idler Roll-10mm Shaft	3	1
4	08780250	Pulley, Idler Assy-54mm	3	1

Parts List, Idler Roller Replacement Kit
08780633

Hydraulic Coupler (Male) Kit

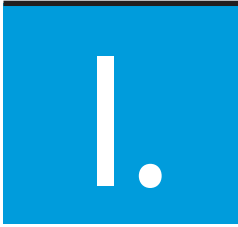

APPENDIX

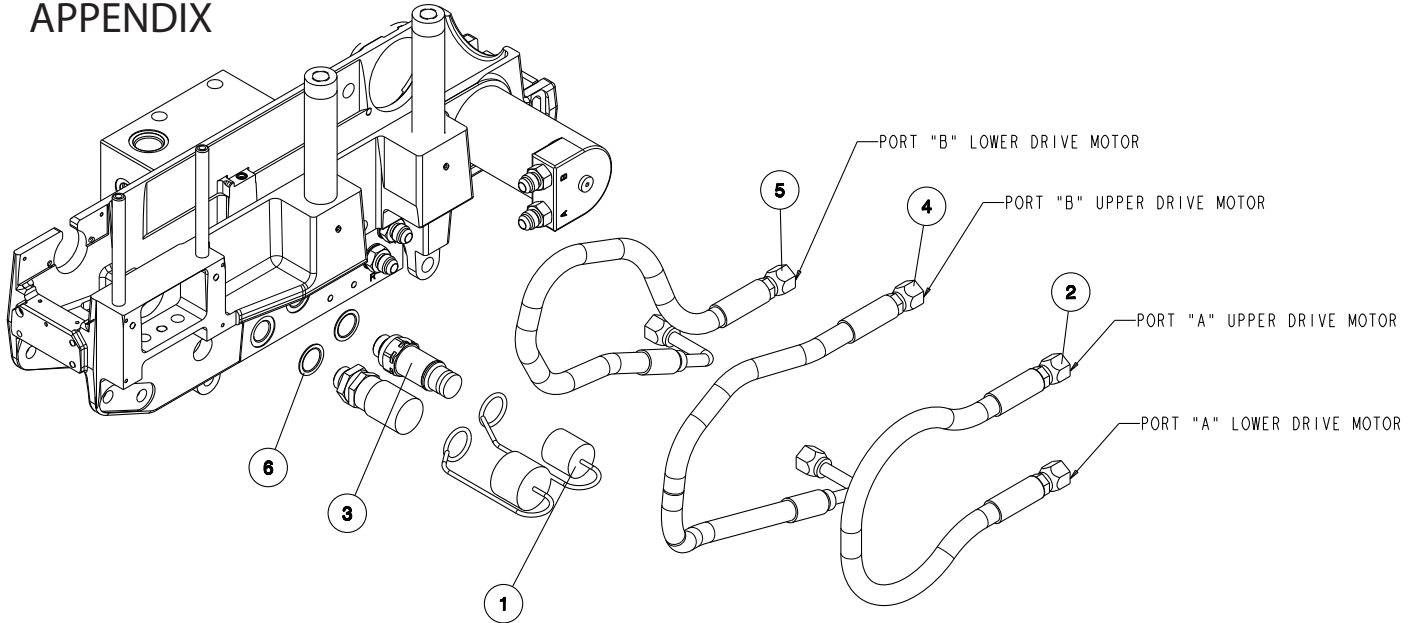

Hydraulic Coupler (Male)
Replacement Kit
08780634

ITEM	PART NO	DESCRIPTION	REQUIRED QTY	KIT QTY
1	02260200	Cap, Dust (Male Flat Face Cplrs)	1	1
2	02286710	Hose 06 x 22.0-06sw	1	
3	02288620	Coupler, Male-Flat Face Metric	1	1
4	02288643	Hose 06 x 21.0-06sw	1	
5	02288643	Hose 06 x 21.0-06sw	1	1
6	02288703	Ftg, Hyd 18mm-Thread Bond Seal	1	
ITEMS 2, 4, 5 ARE NOT INCLUDED IN KIT 08780634				

Parts List, Hydraulic Coupler (Male) Replacement Kit
08780634

Hydraulic Coupler (Female) Kit



APPENDIX

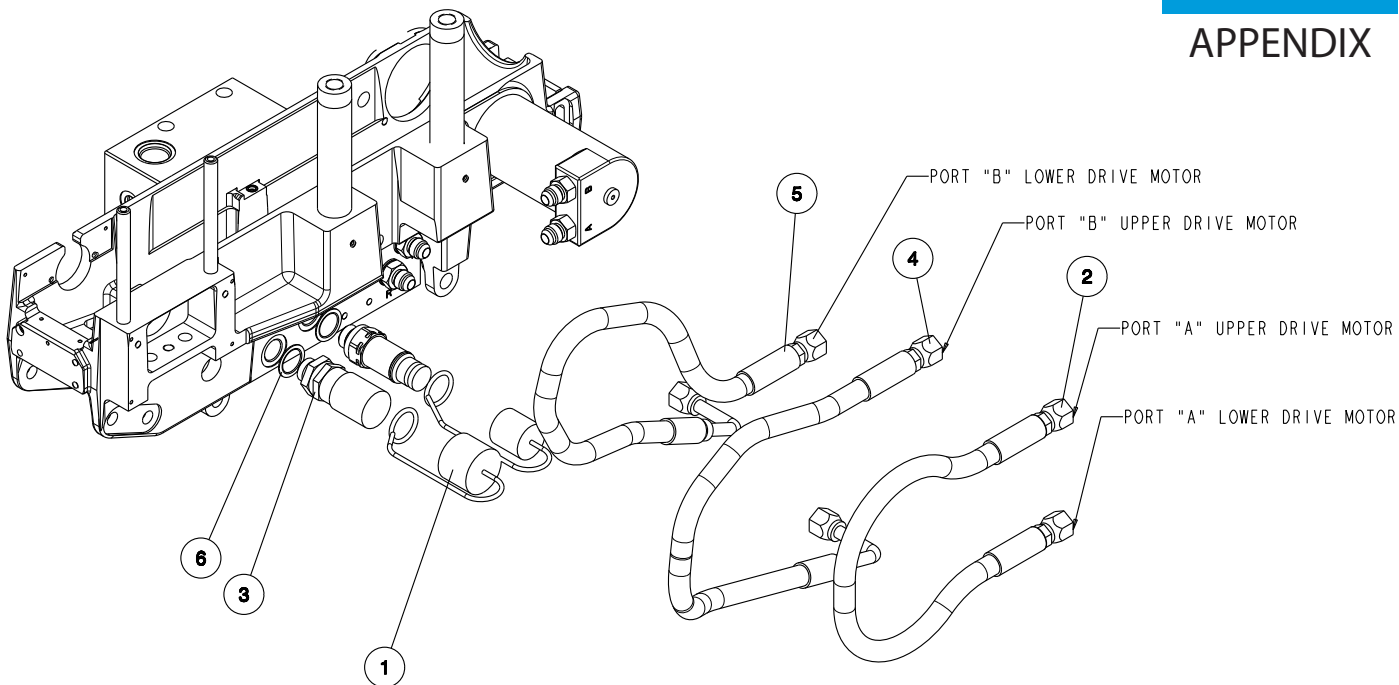

Hydraulic Coupler (Female)
Replacement Kit
08780635

ITEM	PART NO	DESCRIPTION	REQUIRED QTY	KIT QTY
1	02260201	Cap, Dust (Fem Flat Face Cplrs)	1	1
2	02286710	Hose 06 x 22.0-06sw	1	
3	02288619	Coupler, Female-Flt Face Metric	1	1
4	02288643	Hose 06 x 21.0-06sw	1	
5	02288643	Hose 06 x 21.0-06sw	1	
6	02288703	Ftg, Hyd 18mm-Thread Bond Seal	1	1
ITEMS 2, 4, 5 ARE NOT INCLUDED IN KIT 08780634				

Parts List, Hydraulic Coupler (Female) Replacement Kit
08780635

Clamp Adjustment Kit



APPENDIX

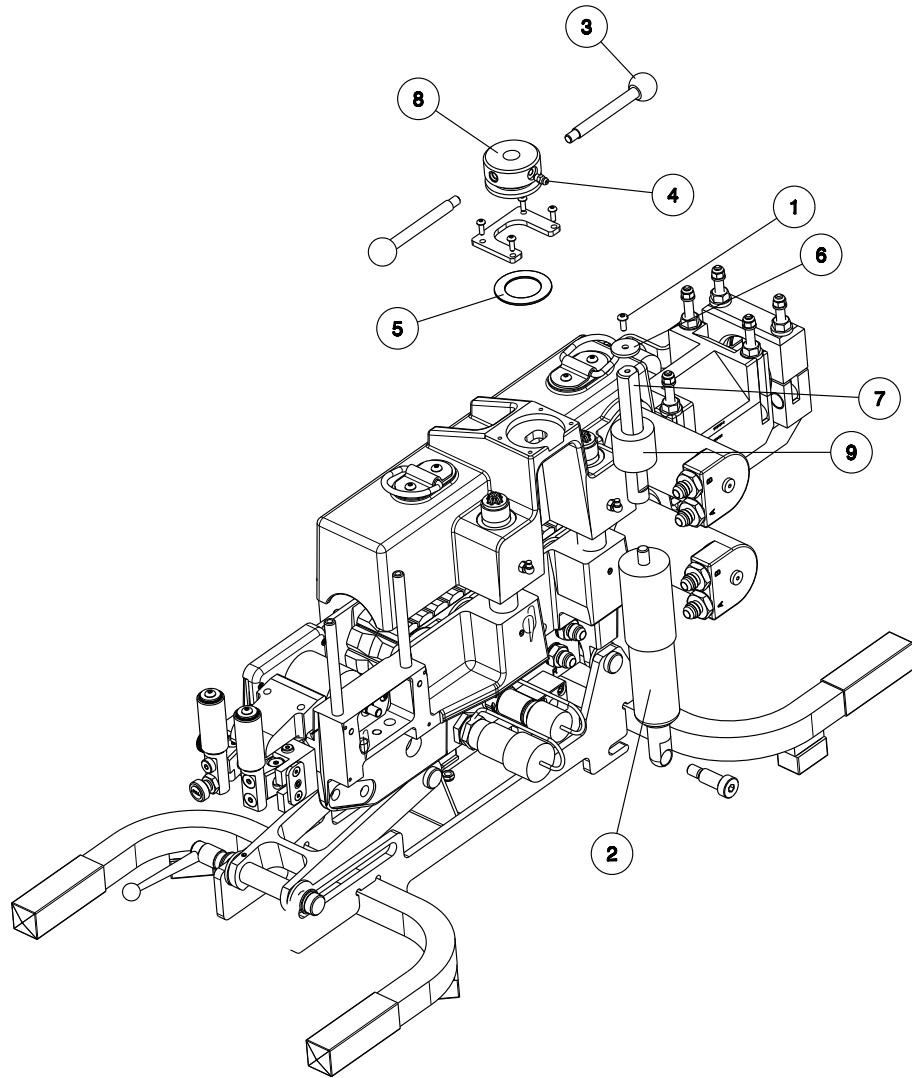

Clamp Adjustment Replacement Kit
08780637

ITEM	PART NO	DESCRIPTION	REQUIRED QTY	KIT QTY
1	02240800	Capsrw, #10-24 x 0.50 BHSS 18-8	1	1
2	02288610	Cylinder, Lift-Pneumatic Chrgd	1	
3	02288644	Lever, Ball Knob 10mm 08mm Thr	2	2
4	02288646	Zerk, Grease, 6mm-1.0 Straight	1	1
5	02289031	Bearing , Thr 1.265-2.0-0.062	1	1
6	02290172	Washer, Fender #10-1.00-.113	1	1
7	08780081	Shaft, Tension Adjustment	1	1
8	08780106	Body, Handle-Clamp Cylinder	1	1
9	08780661	Bushing, Clamp Stopper	1	1
ITEM 2 IS NOT INCLUDED IN KIT 08780637				

Parts List, Clamp Adjustment Replacement Kit
08780637

Lower Counter Roller Kit



APPENDIX

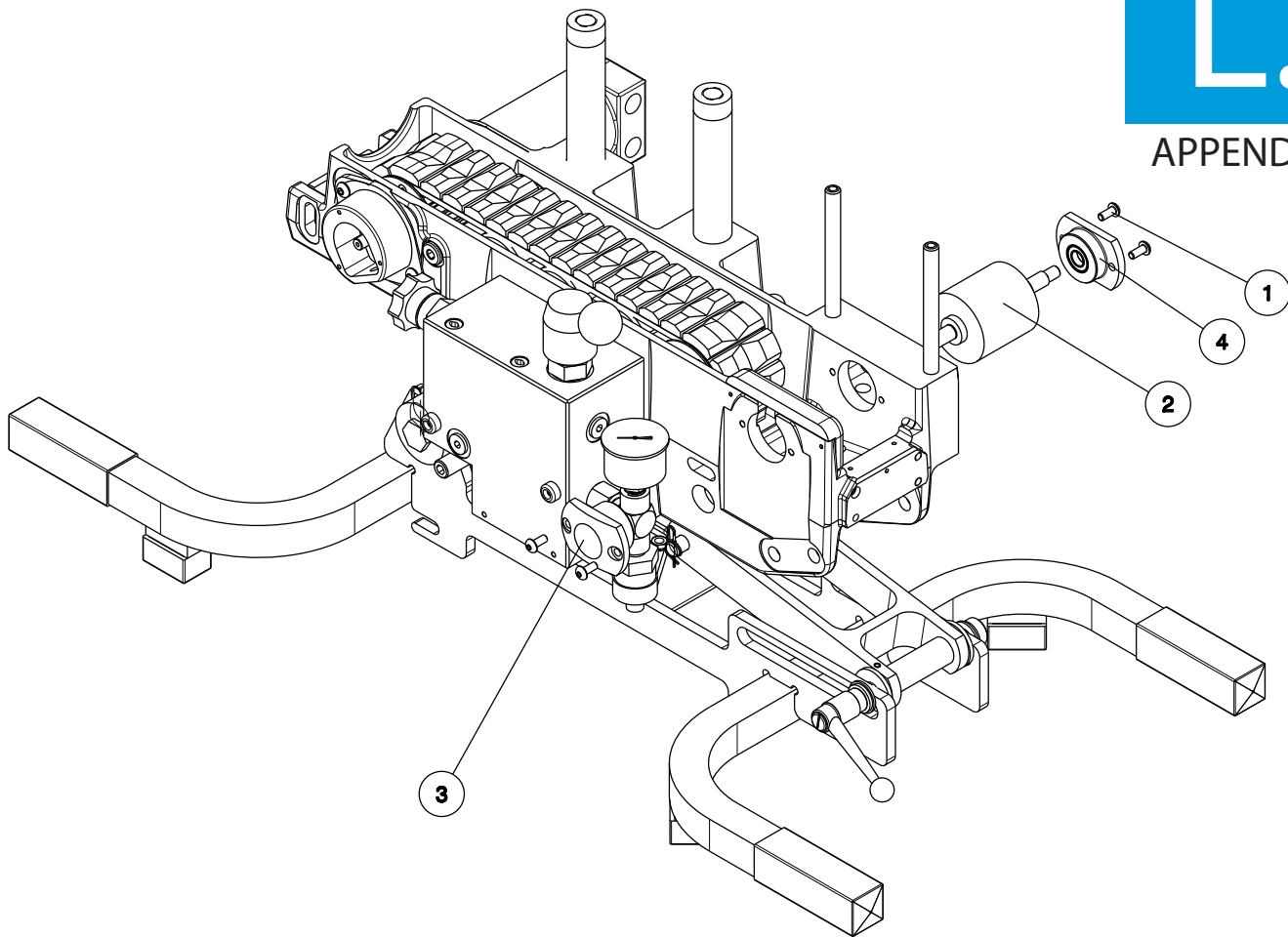

Lower Counter Roller Replacement Kit
08780638

ITEM	PART NO	DESCRIPTION	REQUIRED QTY	KIT QTY
1	02288574	Capsrw, M05-0.8 x 12 BHSS 18-8	4	4
2	08780022	Shaft, Counter (Assy) LW FO Blwr	1	1
3	08780257	Housing, Brg Assy - (Front)	1	1
4	08780260	Housing, Brg Assy - Cntr Rllr	1	1

Parts List, Lower Counter Roller Replacement Kit
08780638

RH Cable Guide Roller Kit & Adjustable Rear Cable Guide Kit

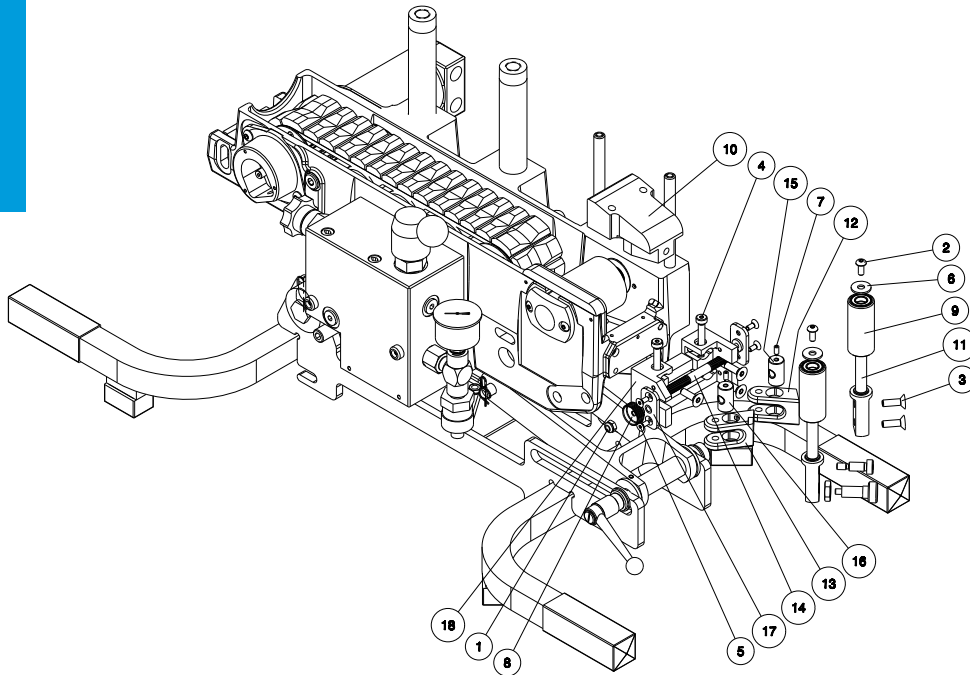

ITEM	PART NO	DESCRIPTION	REQUIRED QTY	KIT QTY	KIT QTY
1	02186901	Nut, #10-24 Nyloc St GR2 CZ	1		1
2	02288574	Capsrw M05-0.8 x 12 BHSS 18-8	6	1	
3	02288584	Capsrw M06-1.0 x 20 CSSS 18-8	5	2	3
4	02288925	Screw, Shoulder M06 Dia-35mm Lg	2		2
5	02288926	Capsrw M04-0.7 x 10 CSSS 18-8	4		4
6	02288989	Flatwasher M06-Fender SS 18-8	2	1	
7	02289053	Setscrew M04-0.7 x 10 HXSO NTST	2		2
8	02290177	Knob, Hand-Knurlled .75 Dia SS	1		1
9	08780133	Roller, Rear Entry (Assy)	2	1	
10	08780135	Pad, Guide-Rear Cable Entry	1		1
11	08780252	Shaft, Vert Guide Roller	1	1	
12	08780473	Arm, Pivot RH-Adj Cbl Guide	1		1
13	08780474	Arm, Pivot LH-Adj Cbl Guide	1		1
14	08780475	Shaft, Adjustment-ADJ CBL Guide	1		1
15	08780476	Pin, Pivot RH-ADJ CBL Guide	1		1
16	08780477	Pin, Pivot LH-ADJ CBL Guide	1		1
17	08780479	Plate, Bearing Mnt Assy	2		2
18	08780481	Block, Pivot Mount Assy	1		1
ITEMS 2, 3, 6, 9, 11 COME IN KIT 08780639					
ITEMS 1, 3, 4, 5, 7, 8, 10, 12, 13, 14, 15, 16, 17, 18 COME IN KIT 08780482					

Parts List, RH Cable Guide Roller Replacement Kit

08780639

LH Cable Guide Roller Kit



APPENDIX

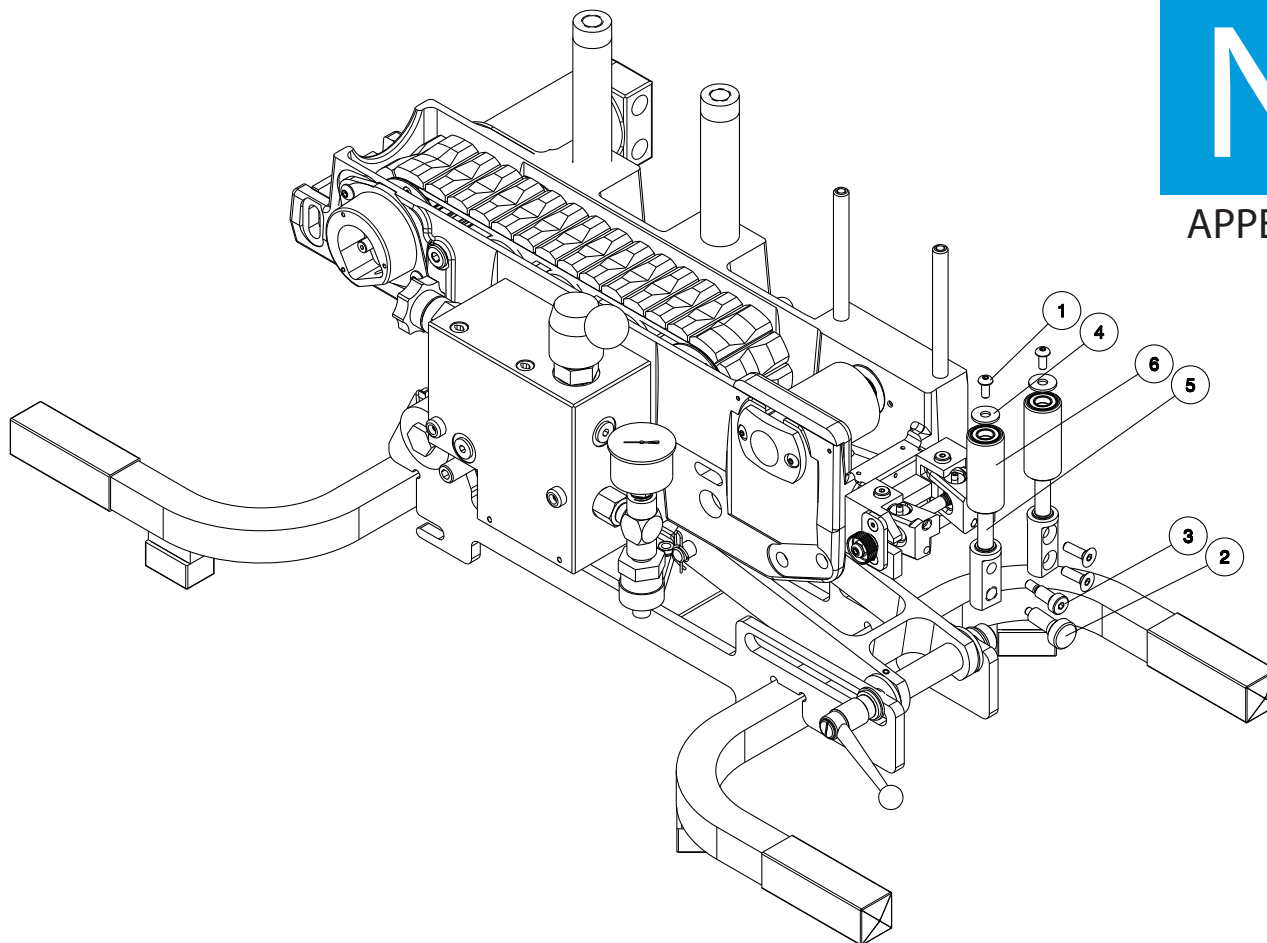

LH Cable Guide Roller Replacement Kit
08780640

ITEM	PART NO	DESCRIPTION	REQUIRED QTY	KIT QTY
1	02288574	Capsrw M05-0.8 x 12 BHSS 18-8	6	1
2	02288579	Plunger, Spring-M10x1.5 SS	1	1
3	02288585	Screw, Shoulder M08 Dia-16mm LG	1	1
4	02288989	Flatwasher M06-Fender SS 18-8	2	1
5	08780059	Shaft, Pivot Guide Roller	1	1
6	08780133	Roller, Rear Entry (Assy)	2	1

Parts List, LH Cable Guide Roller Replacement Kit
08780640

Counter Spring Kit



APPENDIX

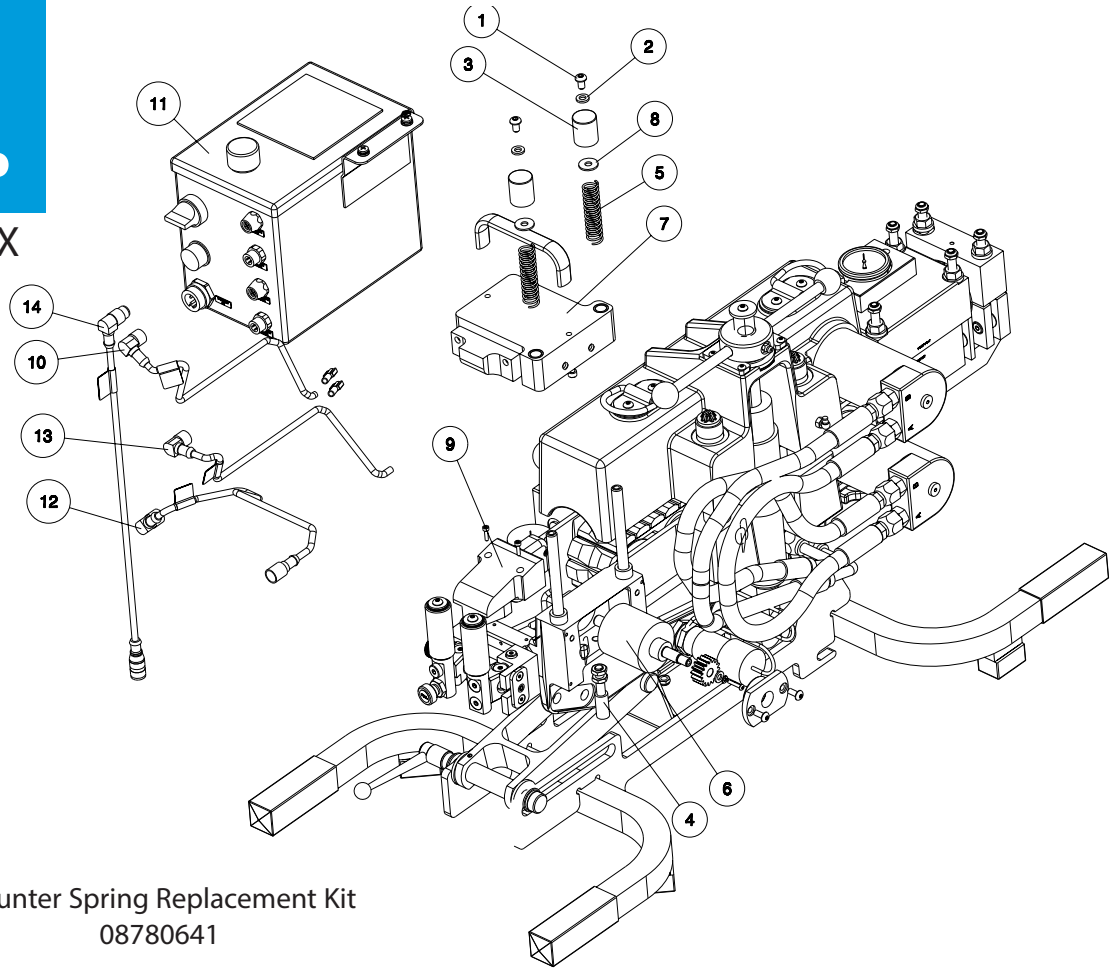

Counter Spring Replacement Kit
08780641

ITEM	PART NO	DESCRIPTION	REQUIRED QTY	KIT QTY
1	02288583	Capsrw M06-1.0x 10 BHSS 18-8	2	1
2	02288588	Flatwshr M06-Narr ST CZ	2	1
3	02288639	Cap, Vinyl .75id-.88od-1.00 Blk	2	1
4	02288677	Sensor, Pickup-Turck Picoprox	1	
5	02288721	Spring, Comprss .063-0.600-2.50	2	1
6	08780022	Shaft, Counter (assy) LW FO Blwr	1	
7	08780090	Clamp, Cable Counter-Assy	1	
8	08780097	Retainer, Spring-Cable Clamp	1	1
9	08780135	Pad, Guide-Rear Cable Entry	1	
10	08780193	Cordset Assy 2pin W/Connectors	2	
11	08781020	Panel, Control-Touch LW Blower	1	
12	08781024	Cordset, Rear Sensor LW Blower	1	
13	08781025	Cordset, Front Sensor LW Blower	1	
14	08781026	Cordset, Transducer LW Blower	1	
ITEMS 4, 6, 7, 9, 10, 11, 12, 13, 14 ARE NOT INCLUDED IN KIT 08780641				

Parts List, Counter Spring Replacement Kit
08780641

Base Mount



APPENDIX

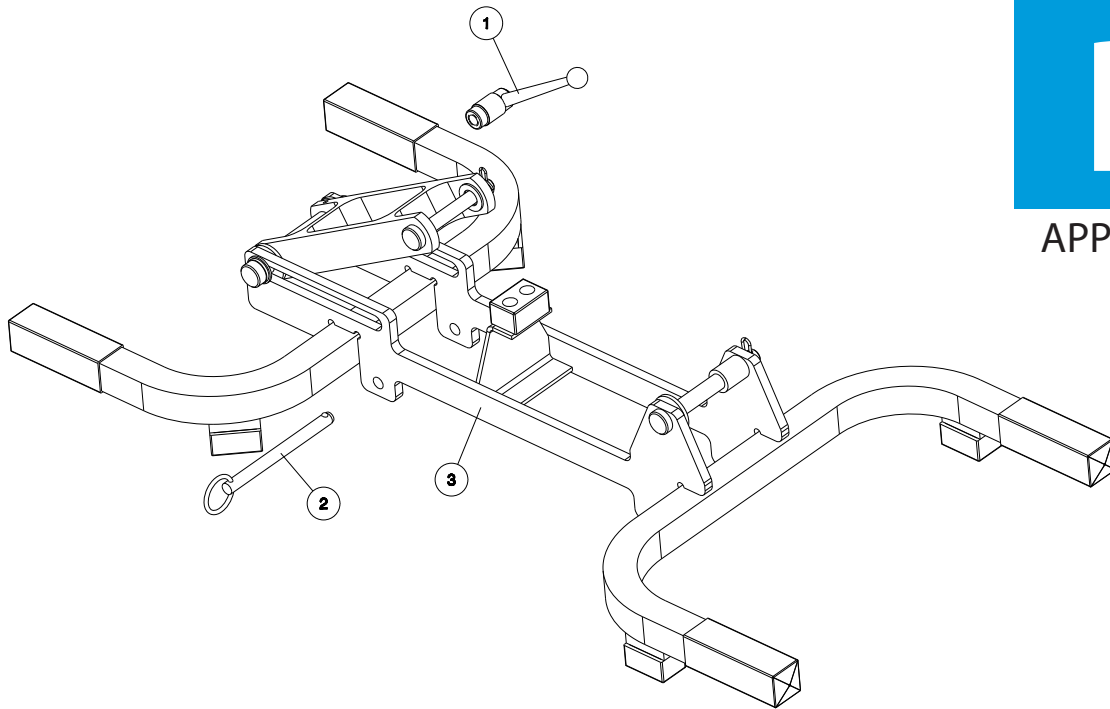

ITEM	PART NO	DESCRIPTION	QTY
1	02288654	Handle, Adjustable Clamping	1
2	02288701	Pin, Hitch Cotterless 3/8 x 4.50	1
3	08780160	Base, Adjustable Assy-LW FO Blowr	1
ITEMS 1 AND 2 INCLUDED WITH ITEM 3			

Base Mount Individual Replacement Parts

Pneumatic & Electrical Circuits



APPENDIX

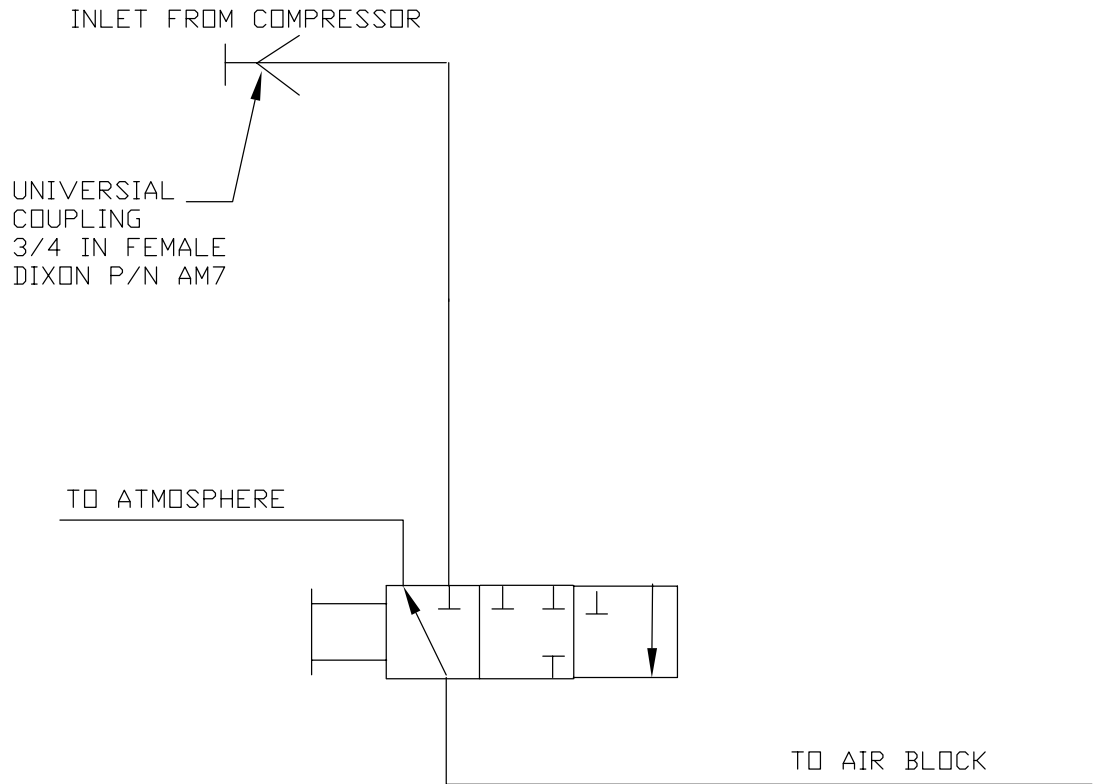

Pneumatic Circuit
08780994

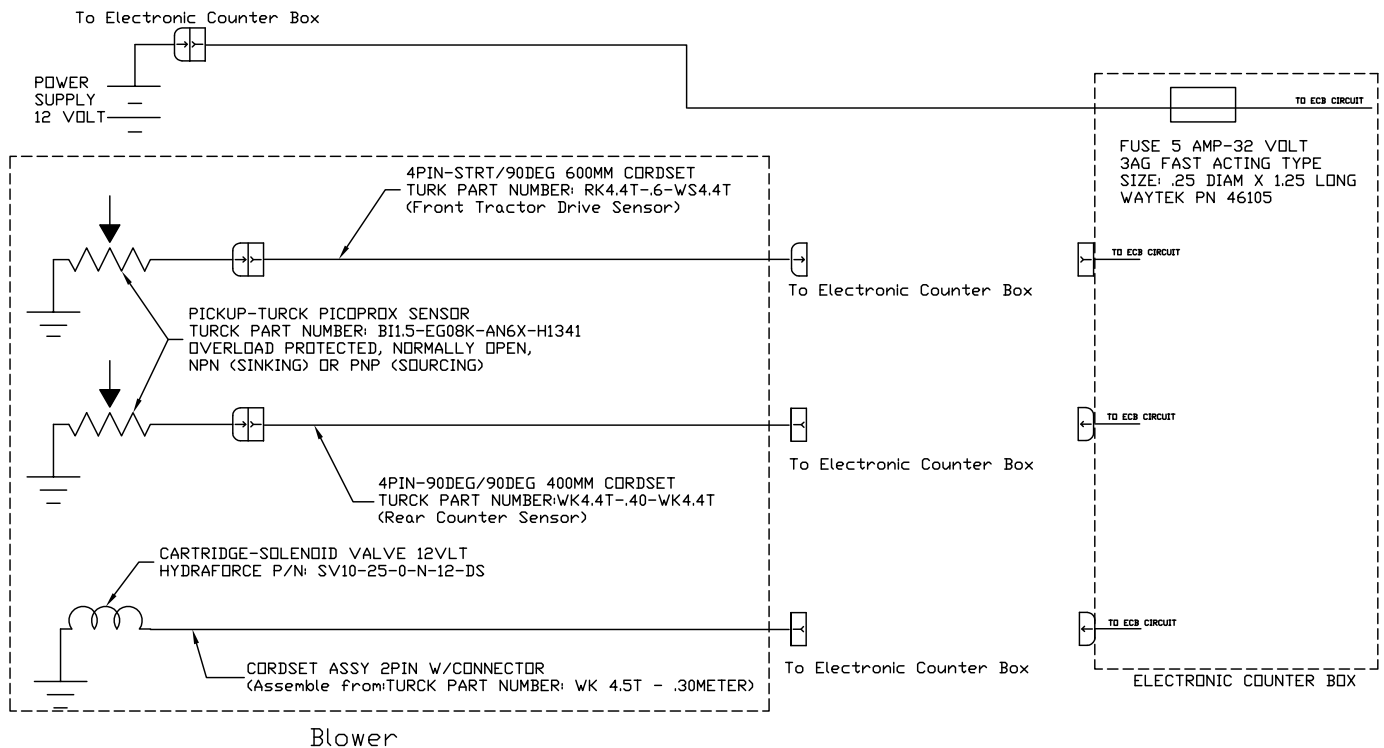

Electrical Circuit
08780996



APPENDIX

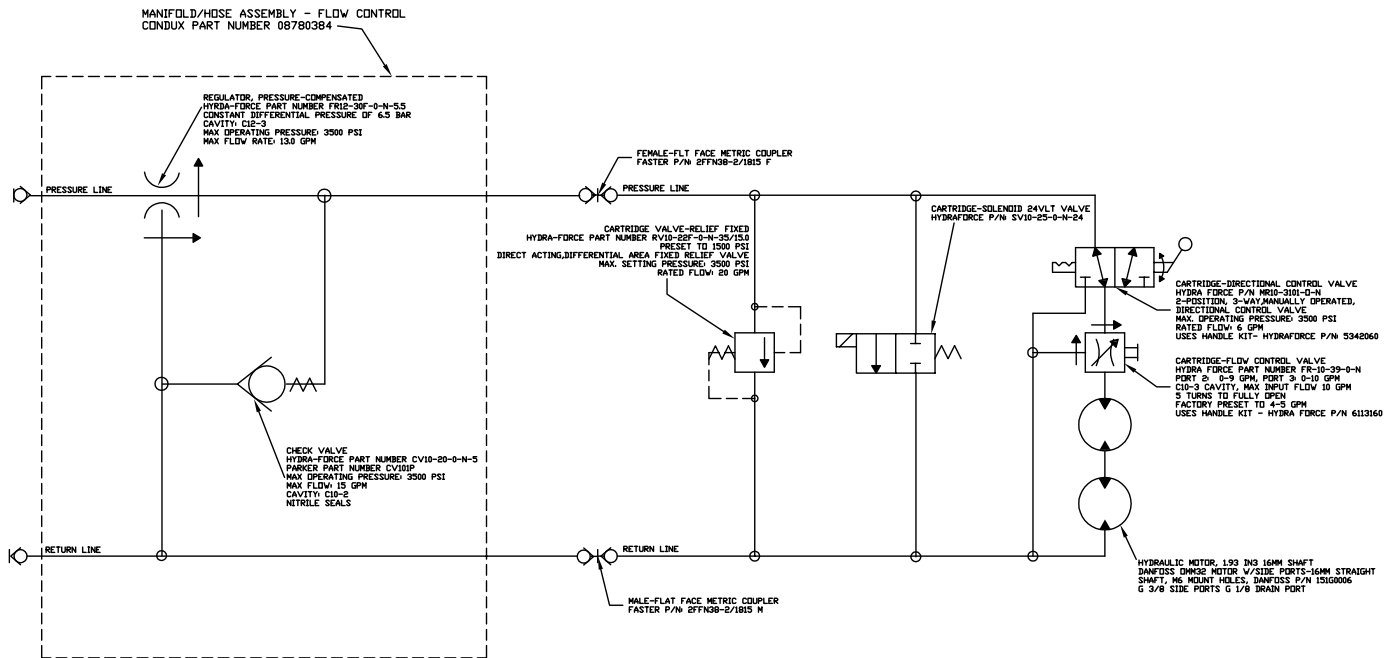

Hydraulic Circuit
08780997

Hydraulic Flow Control Valve



APPENDIX

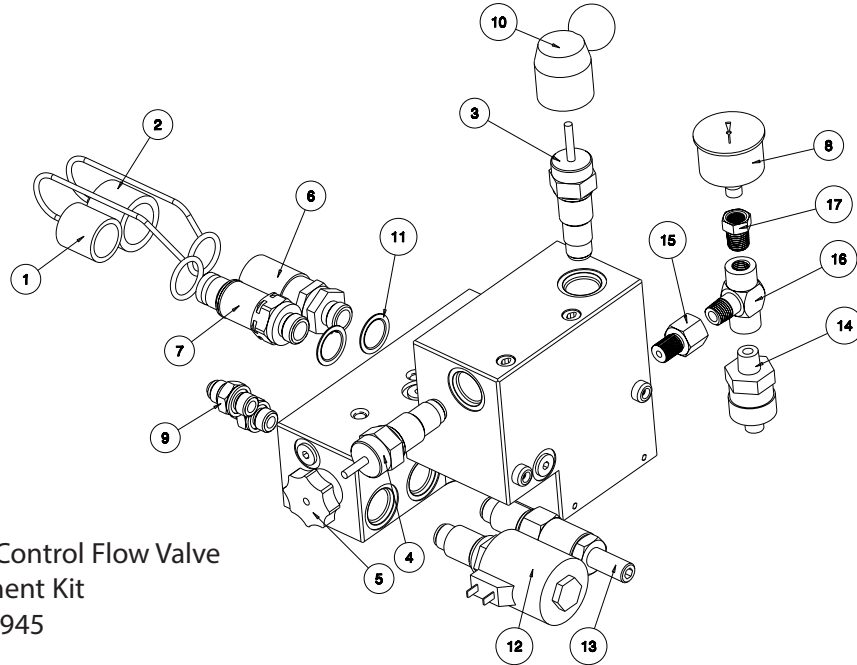

Parts List, Hydraulic Control Flow Valve
Replacement Kit
08780945

ITEM	PART NO	DESCRIPTION	QTY
1	02260200	Cap, Dust (male Flat Face Cplrs)	1
2	02260201	Cap, Dust (fem Flat Face Cplrs)	1
3	02269708	Valve, Cartridge-Direc. Control	1
4	02288589	Valve, Cartridge-Flow Control	1
5	02288590	Knob, Cartridge Valve Flow Ctrl	1
6	02288619	Coupler, Female-Flt Face Metric	1
7	02288620	Coupler, Male-Flat Face Metric	1
8	02288637	Gauge, Press 0-2000 1.50 Bck Mt	1
9	02288638	Ftg, Hyd 06-jic, M14 O-Ring	2
10	02288641	Lever, Ball Handle 2 Pos Detent	1
11	02288703	Ftg, Hyd 18mm-Thread Bond Seal	2
12	02288859	Valve, Cartridge-Solenoid 12vlt	1
13	02290614	Valve, Cartridge-Hex Adj Relief	1
14	02290766	Transducer, Prsr 2000psi-4/20ma	1
15	02290768	Ftg, Hyd 04 O-Ring_m;04 Npt_f	1
16	02290769	Ftg, Hyd 04 Npt_m;04 Npt_f Tee	1
17	02290770	Ftg, Hyd 04 Npt_m;02 Npt_f	1

ECB Upgrade Kit - 08781022

PART NO	DESCRIPTION	QTY
08781020	Panel, Control-Touch LW Blower	1
08781023	Kit, Pressure Transducer-LWB	1

BREAKDOWN of 08781023 Kit

PART NO	DESCRIPTION	QTY
02289187	Bag, 8.00-11.50 Plastic Bubble	1
02290766	Transducer, Prsr 2000psi-4/20ma	1
02290768	Ftg, Hyd 04 O-Ring_M;04 Npt_f	1
02290769	Ftg, Hyd 04 Npt_M;04 Npt_f Tee	1
02290770	Ftg, Hyd 04 Npt_M;02 Npt_f	1
08781026	Cordset, Transducer LW Blower	1

Possible Wear & Replacement Parts

For replacement parts please contact the factory or Condux representative.

List of possible wear items:

Part Number	Description
08780904	Belt, Cable 50MM X 260MM Center
See Table 1, pg 18 for correct cable seal size	Cable Seals
08780126	Kit, Seal Replacement-LW Blower
08780424	Machine Screws,M04-0.7X16 (10)
08780135	Pad, Guide-Rear Cable Entry
08780266	Guide, Cable-Upper Entrance
08780133	Rear Entry Rollers
08780091	Upper Counter Roller
08780022	Lower Counter Roller
See Table 2, pg 18 for correct carrier size	Carrier Seals



APPENDIX

OTHER WEAR OR REPLACEMENT PARTS	
Part Number	Description
08780126	KIT,SEAL REPLACEMENT-LW BLOWER
08780223	PLUG,VENTURI AIR-LW FO BLOWER
08761248	CORD,POWER ASSY W/LIGHTER PLUG
02286416	CORD,EXTENSION-2PIN STRGHT 20'
08780904	BELT,CABLE 50MM X 260MM CENTER
08780135	PAD,GUIDE-REAR CABLE ENTRY
08780266	GUIDE,CABLE-UPPER ENTRANCE
08780133	ROLLER,REAR ENTRY(ASSY)
08780091	ROLLER,CABLE CLAMP-ASSY
08780022	SHAFT,COUNTER(ASSY)LW FO BLWR

BLOWING LUBRICANT	
Part Number	Description
08230600	LUBRICANT, POLY PL2K 1 QT 12/C EA
08230601	LUBRICANT, POLY PL2K 1 GL 4/C EA
08230900	LUBRICANT, POLY WPL2K 1 QT 12/C EA
08230901	LUBRICANT, POLY WPL2K 1 GL 4/C EA
MANUALS	
Part Number	Description
08780998	MANUAL, QUICK REF LW FO BLOWER
08780999	MANUAL, FO CABLE BLOWER

Possible Wear & Replacement Parts

PACKAGE ADD-ONS	
Part Number	Description
08780393	CABLE PACK 0.23"-0.34" (5.8-8.6 MM) CABLE-LW
08780394	CABLE PACK 0.35"-0.60" (8.9-15.2 MM) CABLE-LW
08780395	CABLE PACK 0.61"-0.85" (15.3-21.6 MM) CABLE-LW
08780396	CABLE PACK 0.86"-1.05" (21.7-26.7 MM) CABLE-LW
08780795	DUCT PACK .50" DUCT OD SDR 13.5/ SDR 11
08780680	DUCT PACK .75" DUCT OD SDR 13.5/ SDR 11
08780240	DUCT PACK 1.00" (25 MM) DUCT OD SDR 13.5/ SDR 11
08780385	DUCT PACK 1.25" DUCT OD SDR 13.5/ SDR 11
08780389	DUCT PACK 1.50" (32 MM) DUCT OD SDR 13.5/ SDR 11
08780930	DUCT PACK 2.00" (50.8 MM) DUCT OD SDR 13.5/ SDR 11
08780386	DUCT PACK 33.4MM (1.315) DUCT OD LW
08780387	DUCT PACK 36.0MM (1.417) DUCT OD LW
08780388	DUCT PACK 37.0MM (1.457) DUCT OD LW
08780389	DUCT PACK 38.1MM (1.500) DUCT OD LW (1.25 TRUE)
08780390	DUCT PACK 40.0MM (1.575) DUCT OD LW
08780391	DUCT PACK 42.0MM (1.653) DUCT OD LW
08780392	DUCT PACK 42.2MM (1.660) DUCT OD LW
08780397	DUCT PACK 48.3MM (1.900) DUCT OD LW
08780545	DUCT PACK 44.0MM (1.732) DUCT OD LW
08780460	DUCT PACK 46.0MM (1.811) DUCT OD LW
08780575	DUCT PACK 50.0MM (1.968) DUCT OD LW

Possible Wear & Replacement Parts

CABLE PACK WEAR PARTS	
Part Number	Description
08780406	SEAL,CABLE 0.23-0.28 (5.8-7.3 MM) OD CABLE
08780407	SEAL,CABLE 0.29-0.34 (7.4-8.8 MM) OD CABLE
08761424	SEAL,CABLE 0.35-0.42 (8.9-10.7 MM) OD CABLE
08761425	SEAL,CABLE 0.43-0.48 (10.8-12.2 MM) OD CABLE
08761426	SEAL,CABLE 0.49-0.55 (12.3-14.0 MM) OD CABLE
08761427	SEAL,CABLE 0.56-0.60 (14.1-15.2 MM) OD CABLE
08761428	SEAL,CABLE 0.61-0.67 (15.3-17.0 MM) OD CABLE
08761429	SEAL,CABLE 0.68-0.73 (17.1-18.5 MM) OD CABLE
08761430	SEAL,CABLE 0.74-0.79 (18.6-20.1 MM) OD CABLE
08761431	SEAL,CABLE 0.80-0.85 (20.2-21.6 MM) OD CABLE
08761432	SEAL,CABLE 0.86-0.92 (21.7-23.4 MM) OD CABLE
08761433	SEAL,CABLE 0.93-0.97 (23.5-24.6 MM) OD CABLE
08761434	SEAL,CABLE 0.98-1.04 (24.7-26.4 MM) OD CABLE
08761435	SEAL,CABLE 1.05-1.13 (26.5-28.7 MM) OD CABLE
08780424	MACHINE SCREWS,M04-0.7X16 (10)
08643754	CABLE GRIP- .21- .35-14 1400#
08643755	CABLE GRIP- .32- .48-19 2000#
08643756	CABLE GRIP- .42- .61-21 2500#
08643757	CABLE GRIP- .53- .74-23 3000#
08643758	CABLE GRIP- .64- .87-25 4200#
08643759	CABLE GRIP- .75-1.00-28 4200#
08643137	CABLE GRIP-1.00-1.24-20 6800#

Replacement Parts & Accessories

DUCT PACK WEAR PARTS	
Part Number	Description
08078300	CARRIERS,FOAM 0.75 OD
08761439	CARRIERS,FOAM 1-1/4 OD
08761440	CARRIERS,FOAM 1-1/2 OD
08761441	CARRIERS,FOAM 1-3/4 OD
08761442	CARRIERS,FOAM 2 OD

CARRIER ASSEMBLIES	
08780793	CARRIER ASSY-0.688 OD
08780690	CARRIER ASSY-0.750 OD
08780230	CARRIER ASSY-0.787 OD
08761560	CARRIER ASSY-1.063 OD
08761250	CARRIER ASSY-1.121 OD
08761643	CARRIER ASSY-1.181 OD
08761555	CARRIER ASSY-1.220 OD
08761670	CARRIER ASSY-1.250 OD
08761525	CARRIER ASSY-1.299 OD
08761660	CARRIER ASSY-1.378 OD
08761255	CARRIER ASSY-1.414 OD
08761786	CARRIER ASSY-1.496 OD
08761579	CARRIER ASSY-1.606 OD
08761260	CARRIER ASSY-1.618 OD
08761265	CARRIER ASSY-2.023 OD

CABLE GRIPS	
Part Number	Description
08643131	CABLE GRIP-.75-.99-20 4000#
08643137	CABLE GRIP-1.00-1.24-20 6800#
08643143	CABLE GRIP-1.25-1.49-21 6800#
08643149	CABLE GRIP-1.50-1.99-23 6800#
08643155	CABLE GRIP-2.00-2.46-25 8500#

TOOLS	
Part Number	Description
02284000	3/8" DRIVE RATCHET
02290520	9/16" DEEP WELL SOCKET
02290168	STANDARD & METRIC ALLEN WRENCH SET

Replacement Parts & Accessories

REPLACEMENT DISCS FOR CARRIERS	
08780794	DISC CARRIER-0.688 OD
08780691	DISC CARRIER-0.750 OD
08780235	DISC CARRIER-0.787 OD
08761558	DISC CARRIER-1.063 OD
08761144	DISC CARRIER-1.121 OD
08761646	DISC CARRIER-1.181 OD
08761553	DISC CARRIER-1.220 OD
08761671	DISC CARRIER-1.250 OD
08761528	DISC CARRIER-1.299 OD
08761661	DISC CARRIER-1.378 OD
08761147	DISC CARRIER-1.414 OD
08761785	DISC CARRIER-1.496 OD
08761574	DISC CARRIER-1.606 OD
08761150	DISC CARRIER-1.618 OD
08761153	DISC CARRIER-2.023 OD

DUCT COUPLER CLAMP	
Part Number	Description
08676844	CLAMP,INNERDUCT COUPLER-ASSY
08676830	COUPLING,SPLIT 1.50"/2.00"
08676859	COUPLING,INSRT-1" DCT 1.315 W/S
08676860	COUPLING,INSRT-1.25" DCT 1.66 W/S
08676861	COUPLING, INSRT-1.5" DCT 1.90 W/S
08676862	COUPLING, INSRT-2" DCT 2.37 W/S
08676863	COUPLING, INSERT-40MM DUCT W/S
08676864	COUPLING, INSERT-46MM DUCT W/S

Replacement Parts & Accessories

FIXED HEAD INNERDUCT PULLING EYE

Tapered buttress threads thread into the innerduct for maximum pulling strength. These eyes connect directly to a Condux swivel. When properly sized and installed, these eyes will not pull out of the innerduct until the pulling tensions have greatly exceeded the maximum pulling tensions recommended by the innerduct manufacturers.

NOTE: To determine correct pulling eye size, obtain the actual innerduct inside diameter (I.D.). The I.D. measurement must be greater than dimension A and smaller than dimension B.

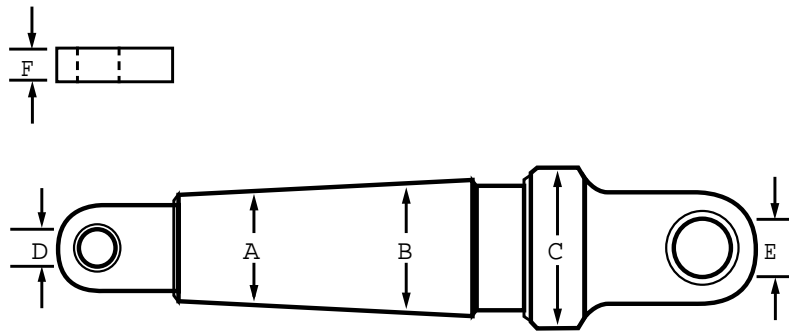

Part Number	Innerduct range		Innerduct ID range		Max OD C		Hole Dia D		Eye Dia E		Thickness F	
	(in)	(mm)	A-B (in)	A-B (mm)	(in)	(mm)	(in)	(mm)	(in)	(mm)	(in)	(mm)
08761840	.5-.75	18-22	.71-.87	18-22	1.25	32	0.25	6	0.5	13	0.5	13
08761842	1-1.25	27-37	1.06-1.43	27-37	1.75	44	0.38	10	0.5	13	0.5	13
08761844	1.5-2	35-43	1.37-1.68	35-43	2	51	0.38	10	0.5	13	0.5	13
08761846	2	45-51	1.80-2.19	46-55	2.5	63	0.38	10	0.5	13	0.5	13

Replacement Parts & Accessories

CABLE JACKET SLITTER

This popular tool makes quick, safe work of removing sheath and turnplate from communication cables. With a turn of the handle, the toothed wheel pulls the tool forward while the angled blade makes a clean cut. Blade guard protects conductors from damage. Also excellent for slitting innerduct. Minimum cable diameter 1" (25 mm).

Part Number	Description
08012900	Cable Jacket Slitter
08012901	Replacement Blade

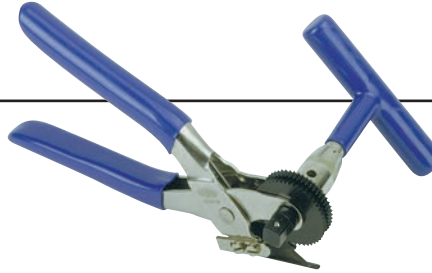

INNERDUCT SLITTER

The Innerduct Slitter is designed for fast, safe cutting of innerducts from 1" (25 mm) to 2" (51 mm) OD.

Part Number	Description
08013100	Innerduct Slitter
08013101	Replacement Blade



TURBOSLITTER™

The TurboSlitter from Condux can easily split HDPE pipe with wall thicknesses ranging from 0.097 to 0.216 inches! The unit quickly adjusts to fit almost any rechargeable drill, 14-volt and larger. Save time and effort on the job with the TurboSlitter from Condux.

Part Number	Description
08010210	Pneumatic Duct Slitter
08010220	Duct Slitter Drill Attachment
08010203	Replacement Blades

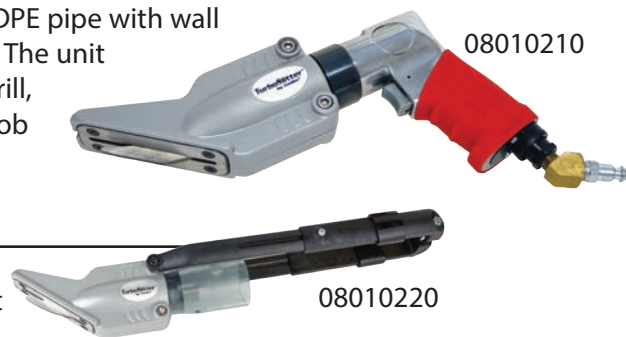

PVC & POLYETHYLENE CUTTER

Razor sharp cutting blade makes a fast, clean, burr-free cut in PVC and polyethylene. Ratcheting handle provides for sure, steady cutting action. Reduces cutting and preparation time.

Part Number	Description
08948050	Small diameter—up to 1¼" (32 mm) conduit with 1½" (38 mm) O.D.
08948070	Large diameter—up to 2" (51 mm) conduit with 2¾" (60 mm) O.D.
08948051	Replacement Blade for Small Cutter
08948071	Replacement Blade for Large Cutter



Replacement Parts & Accessories

INNERDUCT PRESSURE TEST KIT

Use the Innerduct Pressure Test Kit to pressure test innerduct before setting up the Deluxe Blower. The conduit system must be able to withstand and hold 150 psi (10.3 bar) for the Cable Blower to work properly.



Part Number	Description
08761457	Pressure Test Kit for 1", 1 1/4" & 1 1/2" SDR 11 & 13.5 Innerduct <ul style="list-style-type: none"> • Control Valve Assembly • Seal-Off Heads • Pulling Eyes • Pulling Grips • Tool Box
Other Components Available	
Part Number	Description
08034318	Seal-Off Head for 2.00" SDR 11 & 13.5 Innerduct
08761846	Pulling Eye for 2.00" SDR 11 & 13.5 Innerduct
08643155	Pulling Grip for 2.00" SDR 11 & 13.5 Innerduct

POLYWATER® PRELUBE 2000™

Specially formulated for use with fiber optic cable blowing systems, Polywater® Prelube 2000™ has been field proven with the Deluxe Blower. This lubricant is a special lubricant used to prelubricate the conduit system before installing the cable. Prelube 2000 is compatible with all types of cable jackets and conduit types.



Part Number	Description	Std. Pkg. Qty.
08230600	1 Quart (.9 liter) Squeeze Bottle	12/case
08230601	1 Gallon (3.8 liter) Jug	4/case
08230900	1 Quart (.9 liter) Squeeze Bottle, (Winter Grade)	12/case
08230901	1 Gallon (3.8 liter) Jug, (Winter Grade)	4/case

COMFIT COUPLERS

Comfit is a unique Hi-Tech coupler for HDPE cable ducts. Leak tested at 230 PSI and resistant to corrosion and most chemicals.

Comfit is designed in accordance with the special demands of the leading cable duct companies and contractors.

Comfit is excellent for both blowing and pulling methods.

Comfit has a compact profile reducing difficulties traditionally encountered in manholes, narrow trenches and plowing machines.

Comfit's push-fit method ensures fast and simple assembly and disassembly. Push the duct ends into the coupler for a locked and air sealed assembly. No special tools are needed.

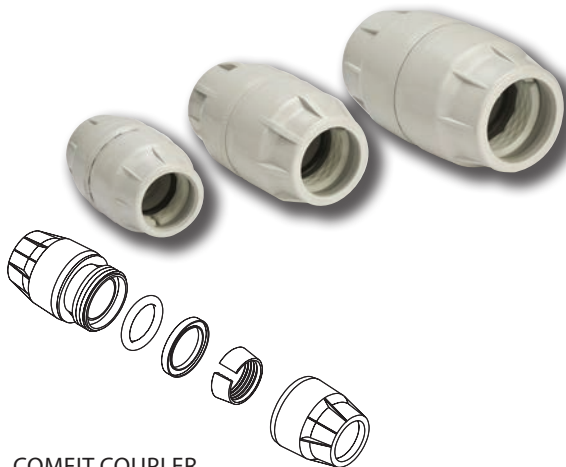

COMFIT COUPLER

Part No.	Nominal OD (mm/inches)	Max Tension	Max Pressure (PSI)	Units per box
08566110	33.4mm / 1"	580	230	70
08566112	42.2mm / 1 1/4"	1130	230	56
08566115	48.3mm / 1 1/2"	1470	230	36
08566120	60.3mm / 2"	2400	230	34

COMFIT PLUG

Part No.	Nominal OD (mm/inches)	Range (inches)	Units per box
08047110	33.4mm / 1"	1.024-1.220	120
08047112	42.2mm / 1 1/4"	1.201-1.535	90
08047115	48.3mm / 1 1/2"	1.496-1.929	60
08047120	60.3mm / 2"	1.85-2.441	35

Warranty Information

16.

A. FACTORY ASSISTANCE

Condux International can provide further advice regarding any problems with the installation, service, assembly, or disassembly of the Deluxe Blower. Call toll free at 1-800-533-2077 (USA and Canada) or 1-507-387-6576 and ask for assistance. The Deluxe Blower can be returned to the factory at any time for service or repair; however, a Return Material Authorization (RMA) must be obtained from Condux before shipping. Condux will not accept returned items without an RMA.

B. LIMITED WARRANTY

Condux International, Inc. extends the following warranty to the original purchaser of these goods for use, subject to the qualifications indicated: Condux International, Incorporated warrants to the original purchaser for use that the goods or any component thereof manufactured by Condux International will be free from defects in workmanship for the period of one year from the date of purchase. Provided such goods are installed, maintained, and used in accordance with Condux's written instructions.

Lack of routine maintenance as specified in the maintenance section of the User's Guide will void the warranty.

Components not manufactured by Condux International but used within the assembly provided by Condux International are subject to the warranty period as specified by the individual manufacturer of said component, provided such goods are installed, maintained, and used in accordance with Condux's and the original manufacturer's written instructions.

Listed wear parts as called out in the User's Guide are not covered under the warranty.

Condux's sole liability and the purchaser's sole remedy for a failure of goods under this limited warranty, and for any and all claims arising from the purchase and use of the goods, shall be limited to the repair and replacement of the goods that do not conform to this warranty.

To obtain repair or replacement service under the limited warranty, the purchaser must contact the factory for a Return Material Authorization (RMA). Once obtained, send the RMA along with the defective part or goods, transportation prepaid, to:

Condux International, Inc.
145 Kingswood Drive
Mankato, MN 56001 USA

THERE ARE NO EXPRESS WARRANTIES COVERING THESE GOODS OTHER THAN AS SET FORTH ABOVE. THE IMPLIED WARRANTIES OR MERCHANTABILITY AND FITNESS FOR A PARTICULAR PURPOSE ARE LIMITED IN DURATION TO ONE YEAR FROM DATE OF PURCHASE.

CONDUX ASSUMES NO LIABILITY IN CONNECTION WITH THE INSTALLATION OR USE OF THIS PRODUCT, EXCEPT AS STATED IN THIS LIMITED WARRANTY. CONDUX WILL IN NO EVENT BE LIABLE FOR INCIDENTAL OR CONSEQUENTIAL DAMAGES.



Condux International, Inc.

P.O. Box 247 • 145 Kingswood Drive, Mankato, MN 56002-0247 USA

1-507-387-6576 • 1-800-533-2077 • FAX 1-507-387-1442

Internet: <http://www.condux.com> • e-mail: cndxinfo@condux.com

© Copyright 2013, Condux International, Inc.

Printed in USA

Literature Part Number: 08780999

Revision Number: 4.1