

Crimp-On Pulling Eyes

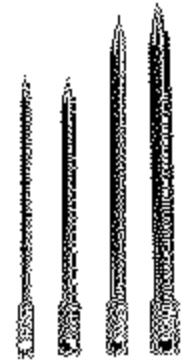
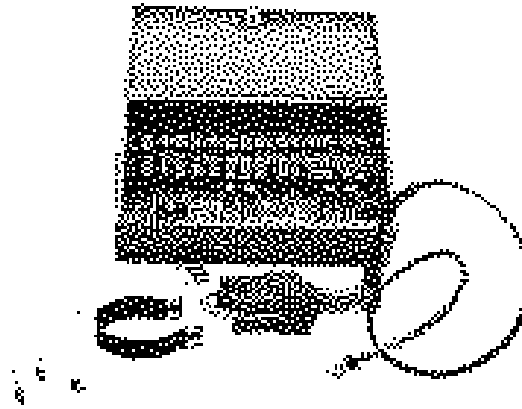
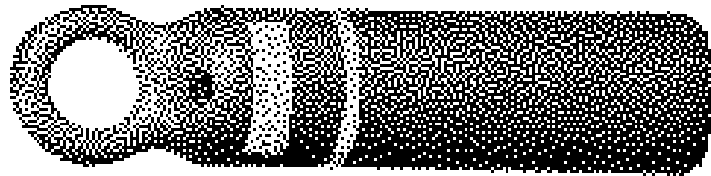

Important Safety Notice

Read and understand all procedures and safety instructions before installing Condux Cable Pulling Eyes. Observe all safety information on this page and note specific safety requirements as explained by procedures called out in this manual. Failure to follow these instructions could result in serious personal injury or death.

ADVERTENCIA:

Favor de leer y comprender todas las instrucciones de operación y seguridad antes de usar la máquina. Si Ud. no comprende las instrucciones favor de consultarle a su jefe.



Save this user's guide for future reference.



If you have questions on:

SAFETY - OPERATIONS - APPLICATIONS

CALL 1-800-533-2077 or 1-507-387-6576

Table of Contents

	General Information	4
	a. The Condux Pulling Eye	4
	b.	
	Crimper Kit and Accessories.	5
	c. Types of Condux Pulling Eyes.	6
	Installing a Crimp-On Telephone Pulling Eye.	7
	a. Preparing the Cable - The Centering Tool.	7
	b. Telephone Cable Pulling Eye Selection.	8
	c. Marking the Cable Before Installation	9
	d. Driving the Pulling Eye onto the Cable.	9
	e. Crimper Die Selection.	10
	f. Crimper Cable Selection.	10
	g. Attaching the Crimper Cable.	10
	h. Crimping the Pulling Eye.	12
	i. Procedure for Gel or Grease Filled Cable.	13

General Information

1.

A. THE CONDUIT PULLING EYE



A pulling eye for telephone cable is made of a forged eye pad, a length of tube, and a barbed spike. When crimping on the end of a cable, it allows you to successfully pull cable into any type of duct system.

The pulling eye is driven onto the end of the cable and crimped into place. The crimp takes place between the barbs on the spike, which is inside of the tube and the tube itself. This crimp grips 100% of the conductors and assures maximum pulling strength when pulling cable into your duct system. The pulling eye also seals the end of the cable. This will keep pressure in and water out.

B. CRIMPER KIT AND ACCESSORIES

Items needed to crimp pulling eyes onto cable:

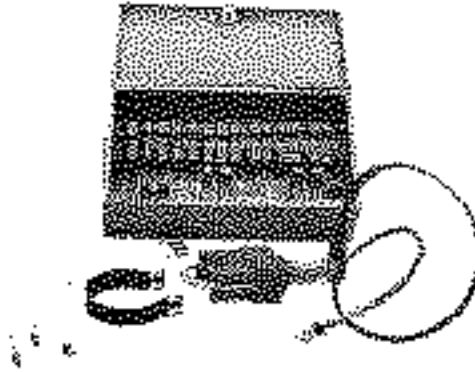

1. The Crimper Kit - The kit has capabilities of crimping pulling eyes with inside diameters of 0.555 to 3.620 inches. The kit contains the crimper dies, crimper cables, crimper base and hydraulic ram, cable guard, and the hydraulic hose and couplings. Condux part number 08920000.

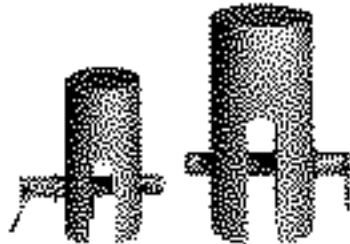

2. Driving Tool - The driving tool is used for driving the pulling eye onto the cable. This is an important tool to keep the pulling eye from being damaged during installation.



3. Centering Tool - By driving the centering tool into the end of the communications cable, you force some of the grease out and separate the wire pairs. This provides a passage in the center of the cable for the pulling eye spike to follow into.

4. Hydraulic Pump - The pump is used to supply hydraulic pressure to the crimper ram which crimps the eye to the cable.

5. Measuring Tape - The measuring tape is used for determining the size of the cable and for ensuring complete seating of the eye on the cable.

6. Sledge Hammer - For driving the centering tool into the cable and for driving the pulling eye onto the cable when using the driving tool.

C. TYPES OF CONDUIT PULLING EYES

Use the following to determine the type of pulling eye you need:

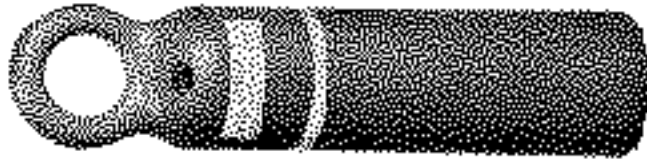

3-Crimp pulling eye with port - for standard cut length cables of under 600 feet that are gel or grease-filled or are to be pressurized.

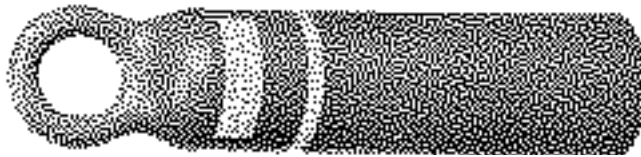

3-Crimp pulling eye without port - for standard cut length cables of under 600 feet.

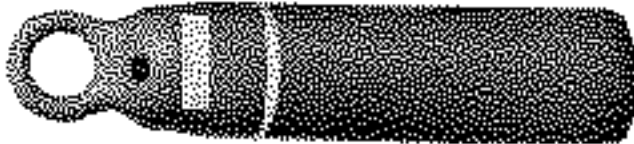

4-Crimp pulling eye with port - for all types of gel or grease filled or pressurized cable.

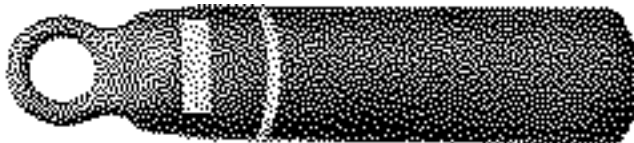

4-Crimp pulling eye without port - for air core cable when you are not going to pressurize cable from the pulling eye end.

Installing a Crimp-On Telephone Pulling Eye

2.

A. PREPARING THE CABLE - THE CENTERING TOOL



First, it is recommended that you square off the end of the cable. This ensures that the pulling eye will go on as far as possible.



From the chart below, locate the proper centering tool. Place the centering tool on the end of the cable as close to the center as possible. Drive the centering tool into the cable up to the head of the centering tool. This will push some of the grease from the cable and separate the wire pairs, making way for the spike inside of the pulling eye.

Cable O.D. Up To (in.)	Cable O.D. Up To (mm)	Centering Tool Part Number
1.055	27	08945011
1.152	29	08945011
1.277	32	08945015
1.402	36	08945015
1.527	39	08945015
1.652	42	08945021
1.777	45	08945021
1.902	49	08945021
2.027	51	08945021
2.152	55	08945021
2.277	32	08945027

Cable O.D. Up To (in.)	Cable O.D. Up To (mm)	Centering Tool Part Number
2.402	61	08945027
2.527	64	08945027
2.652	68	08945027
2.777	70	08945027
2.902	74	08945029
2.995	76	08945029
3.140	79	08945034
3.245	83	08945034
3.370	86	08945034
3.495	89	08945034
3.620	92	08945043

B. TELEPHONE CABLE PULLING EYE SECTION

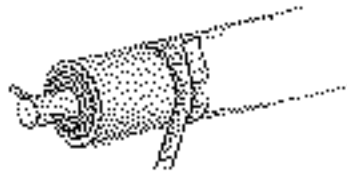

With the centering tool still in the cable, measure the diameter of the cable. With this measurement, select the proper pulling eye size from the chart below. The inside diameter of the pulling eye should be slightly larger than the outside diameter of the cable you are crimping a pulling eye onto.

Inside Dia. of Pulling Eye (in.)	Inside Dia. of Pulling Eye (mm)	4-Crimp Pulling Eye Without Valve Port	3-Crimp Pulling Eye Without Valve Port	4-Crimp Pulling Eye With Valve Port	3-Crimp Pulling Eye With Valve Port
0.950	24		08911009		
1.055	27		08911010		
1.152	29	08910011	08911011	08919011	08919511
1.277	32	08910012	08911012	08919012	08919512
1.402	36	08910014	08911014	08919014	08919514
1.527	39	08910015	08911015	08919015	08919515
1.652	42	08910016	08911016	08919016	08919516
1.777	45	08910017	08911017	08919017	08919517
1.902	49	08910019	08911019	08919019	08919519
2.027	51	08910020	08911020	08919020	08919520
2.152	55	08910021	08911021	08919021	08919521
2.277	58	08910022	08911022	08919022	08919522
2.402	61	08910024	08911024	08919024	08919524
2.527	64	08910025	08911025	08919025	08919525
2.652	68	08910026	08911026	08919026	08919526
2.777	70	08910027	08911027	08919027	08919527
2.902	74	08910028	08911028	08919028	08919528
2.995	76	08910029	08911029	08919029	08919529
3.140	79	08910031	08911031	08919031	08919531
3.245	83	08910032	08911032	08919032	08919532
3.370	86	08910033	08911033	08919033	08919533
3.495	89	08910034	08911034	08919034	08919534
3.620	92	08910036	08911036	08919036	08919536

C. MARKING THE CABLE BEFORE INSTALLATION

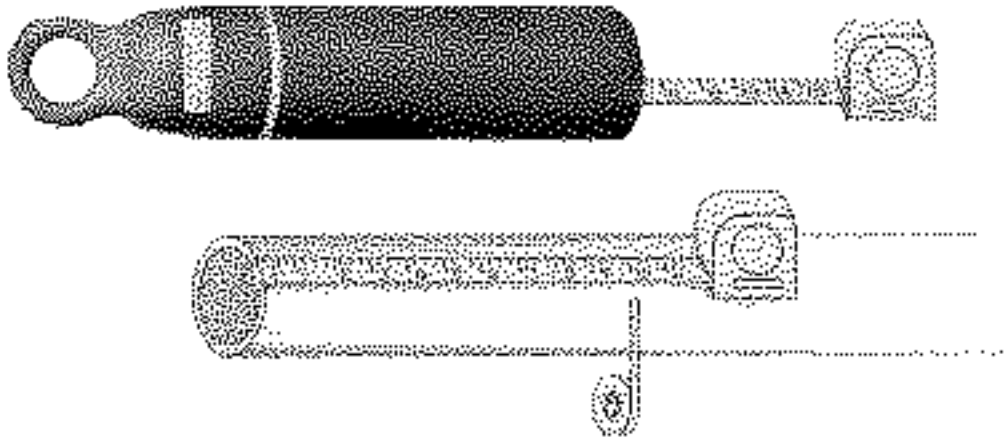

Measure the inside depth of the pulling eye. Mark this length on the squared end of the cable. At this time, remove the centering tool from the end of the cable. There should remain a well in the end of the cable.

D. DRIVING THE PULLING EYE INTO THE CABLE

Choose the proper driving tool from the following chart:

Driving Tool Size	Pulling Eye Inside Diameter	Driving Tool Part Number
1½" Dia.	0.950 - 1.277	08940000
2¼" Dia.	1.402 - 2.527	08940001
3" Dia.	2.652 - 3.620	08940002

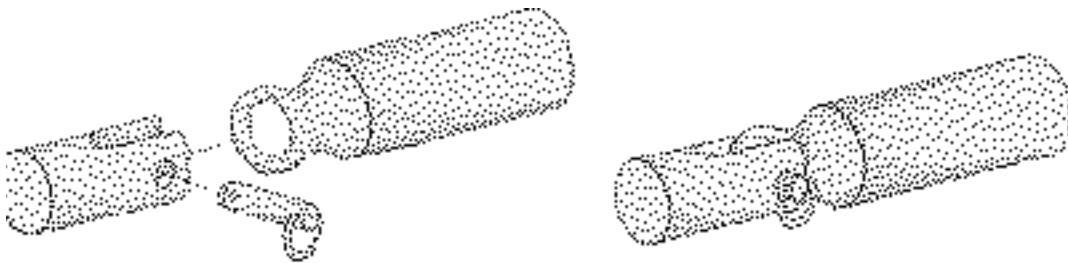

Remove the pin from the driving tool, slip the driving tool over the eye portion of the pulling eye, and put the pin back into place. Place the pulling eye-driving tool combination onto the cable. By hand, push the pulling eye onto the cable as far as possible. With a sledge hammer, drive the pulling eye onto the cable the remainder of the way. Make sure you drive the eye up to the line that you marked on the cable. This ensures that you have the pulling eye completely on the cable.

E. CRIMPER DIE SELECTION

Now that the pulling eye is on the cable, you must get the crimper ram ready to crimp on the pulling eye. Go to the chart below and select the proper crimper die for the size pulling eye you will be using. Take the die and snap it into the end of the ram on the crimper assembly.

F. CRIMPER CABLE SELECTION

From the chart, locate the proper crimper cable based on the pulling eye inside diameter.

Pulling Eye Inside Diameter		Crimper Die	Crimper Cable
(in.)	(mm)		
0.050	2.1	08020011	08020002

G. ATTACHING THE CRIMPER CABLE

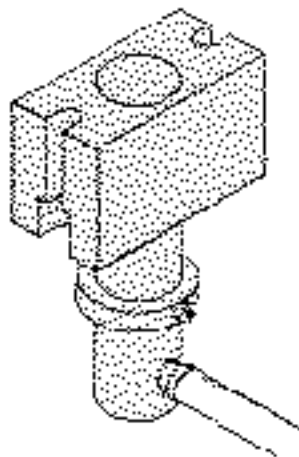

Loosen the setscrew in the retaining ring and pull it down away from the base.

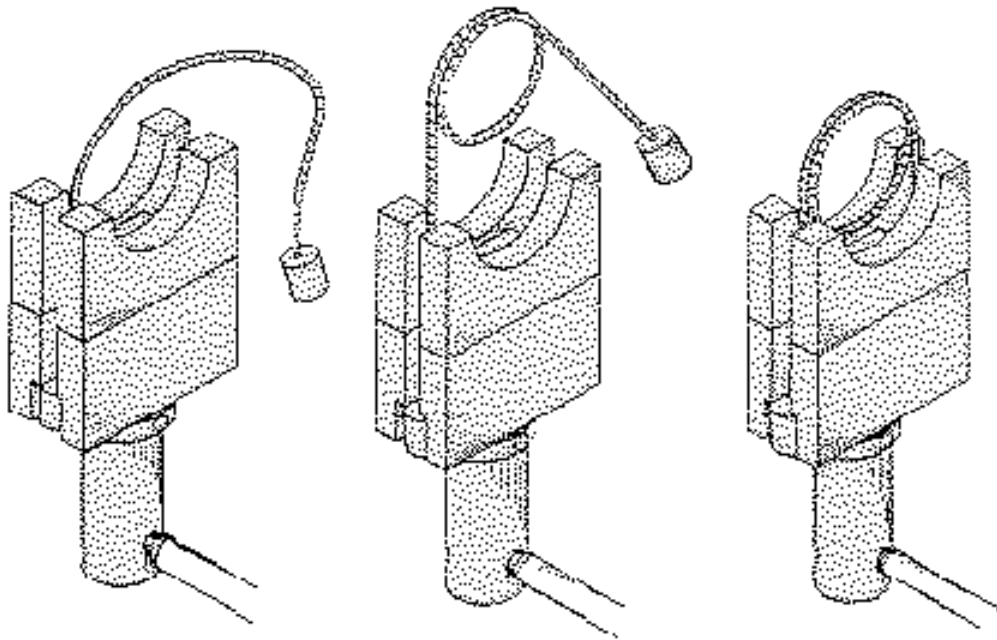

Insert the ferrule on one end of the crimper cable into the pocket in the base. The cable should then pass up through the die. Make a loop with the cable and pass the cable back down through the slot on the opposite side of the die. Then insert the ferrule into the other pocket in the base. Bring the retaining ring back up tight against the base of the crimper cable and tighten the setscrew. This locks the cable into the base.

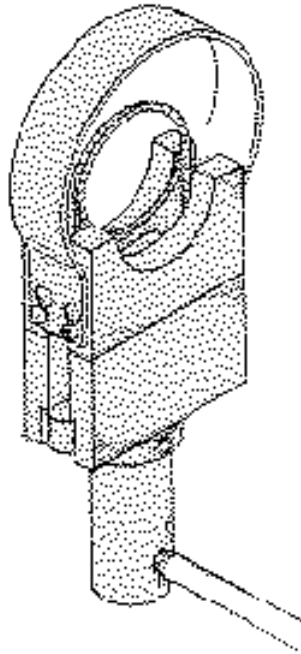

With the cable in place, snap the crimper die out of the ram and lift it away slightly. Do not lift it out from between the crimper cable. Install the guard by slipping it over the shoulder pins and thumb screws in the base. Pull up on the guard and tighten down the two thumb screws. Snap the crimper die back into the ram.

Attach the hose from the crimper ram to a 10,000 psi hydraulic pump. Once the pump is attached to the ram, cycle the ram a couple of times to make sure everything is in proper working order. You are now ready to crimp the pulling eye onto the cable.

H. CRIMPING THE PULLING EYE

To make the first crimp, pick up the crimper assembly and place the loop in the cable around the pulling eye. Place the crimper cable directly over the marked line closest to the head of the pulling eye. By placing the crimp on the marked line, you are making sure that the crimp is made into the recess of the spike, which is inside the tube of the pulling eye.

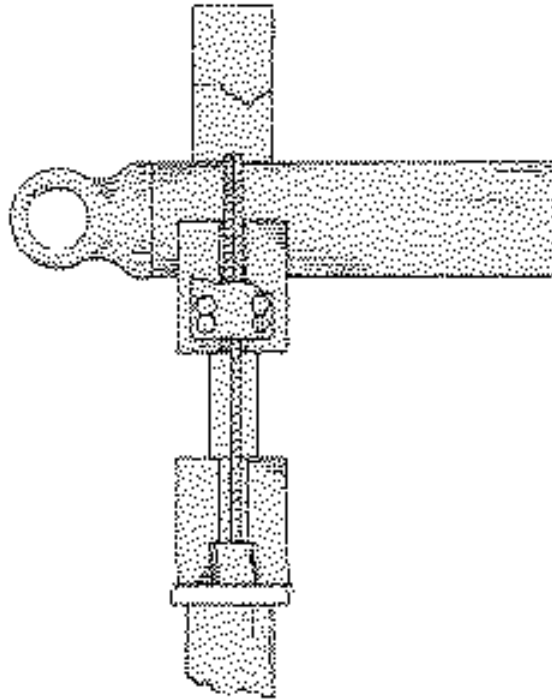

Run the ram out on the crimper assembly to pull the cable tight around the pulling eye. Check to make sure the cable is still centered over the marked line. Also, check to make sure the crimper cable doesn't cross over itself in making the loop. The cable will wear prematurely and may fracture if crossed over itself while crimping on the tube.

!NOTE: To extend the life of the crimper cable, lubricate the cable with a spray lubricant while crimping.



1st ROTATION



2nd ROTATION

Continue to run the ram out. The crimper cable will collapse the wall of the pulling eye tube. Apply pressure until the depth of the crimp is approximately $\frac{1}{2}$ of the diameter of the crimper cable. Release the pressure to the crimper assembly.

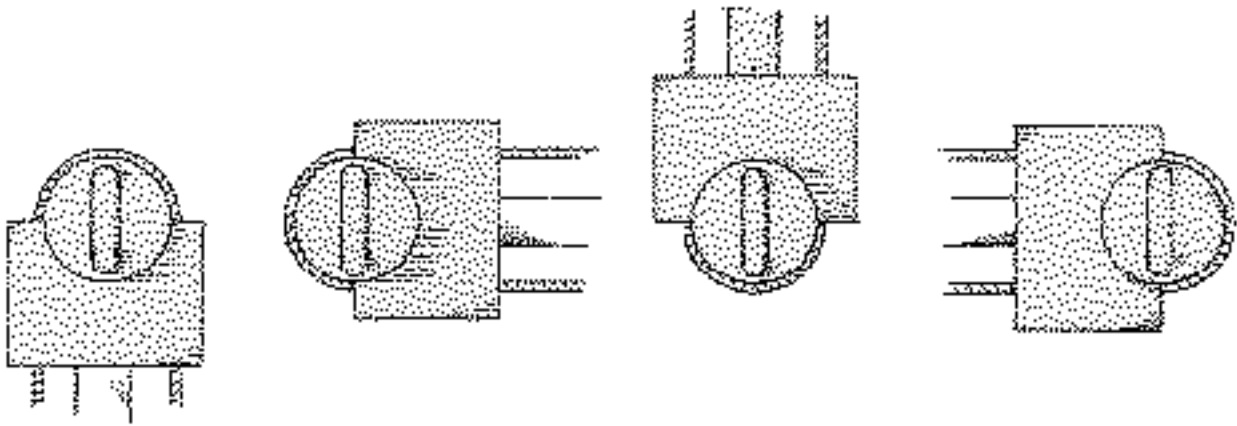

Rotate the crimper assembly 90° on the pulling eye tube. Again extend the ram causing the cable to crimp the pulling eye tube to a depth of ½ the crimper cable diameter. Do this 4 times on the first rotation, 360° around the pulling eye. On the second 360° rotation, crimp to the full depth of the crimper cable diameter. This procedure will require the ram to be extended 8 times per crimp.

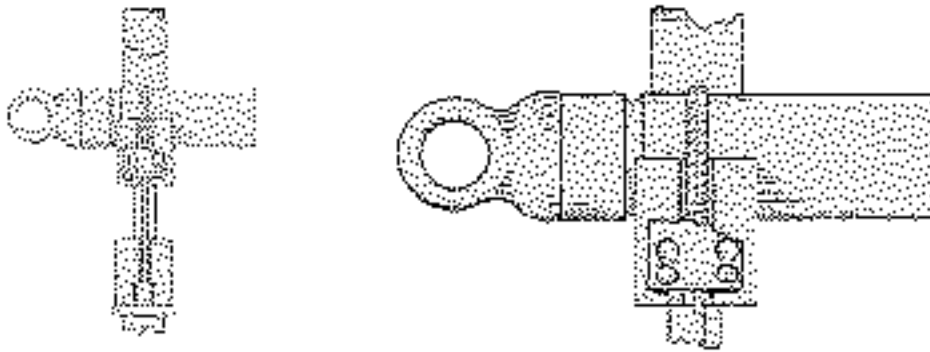

Slide the crimper assembly down the pulling eye to make the second crimp. Line up the edge of the crimper die directly over the center of your first crimp. Repeat the procedure of rotating and crimping as when making the first crimp.

The 3rd and 4th crimps are made in the same manner: first by locating the crimper die edge over the last crimp and then the rotating sequence of the crimper assembly.

I. PROCEDURE FOR GEL OR GREASE-FILLED CABLE

When choosing the pulling eye for gel or grease-filled cable, a pulling eye WITH VALVE PORT must be used. After completing steps A through G, a pulling eye should be installed on a gel or grease-filled cable using the following procedure:

Remove the pressure port plug from the pulling eye before driving it onto the cable. On the first crimp, only crimp to approximately one-half the diameter of the crimper cable. Proceed to the second and third crimps, again crimping to approximately one-half the diameter of the crimper cable.

On the fourth crimp (third crimp on the 3-Crimp series) crimp to the full diameter of the crimper cable. Then return to the third crimp and crimp it to full depth, then the second, and finally the first.

This procedure will expel most of the gel or grease through the pipe plug port in the pulling eye head. Replace the pipe plug.

Notes

Warranty Information

A. FACTORY ASSISTANCE

Condux International can provide further advice regarding any problems with the installation, service, assembly, or disassembly of Condux Pulling Eyes . Call toll free at 1-800-533-2077 (USA and Canada) or 1-507-387-6576 and ask for assistance. The Condux Pulling Eyes can be returned to the factory at any time for service or repair; however, a Return Material Authorization (RMA) must be obtained from Condux before shipping. Condux will not accept returned items without an RMA.

B. LIMITED WARRANTY

Condux International, Inc. extends the following warranty to the original purchaser of these goods for use, subject to the qualifications indicated:

Condux International, Incorporated warrants to the original purchaser for use that the goods or any component thereof manufactured by Condux International will be free from defects in workmanship for the period of one year from the date of purchase, provided such goods are installed, maintained, and used in accordance with Condux's written instructions.

Components not manufactured by Condux International but used within the assembly provided by Condux International are subject to the warranty period as specified by the individual manufacturer of said component, provided such goods are installed, maintained, and used in accordance with Condux's and the original manufacturer's written instructions.

Condux's sole liability and the purchaser's sole remedy for a failure of goods under this limited warranty, and for any and all claims arising out of the purchase and use of the goods, shall be limited to the repair and replacement of the goods that do not conform to this warranty.

To obtain repair or replacement service under the limited warranty, the purchaser must contact the factory for a Return Material Authorization (RMA). Once obtained, send the RMA along with the defective part or goods, transportation prepaid, to:

Condux International, Inc.
145 Kingswood Road
Mankato, MN 56001 USA

THERE ARE NO EXPRESS WARRANTIES COVERING THESE GOODS OTHER THAN AS SET FORTH ABOVE. THE IMPLIED WARRANTIES OR MERCHANTABILITY AND FITNESS FOR A PARTICULAR PURPOSE ARE LIMITED IN DURATION TO ONE YEAR FROM DATE OF PURCHASE.

**CONDUX ASSUMES NO LIABILITY IN CONNECTION WITH THE INSTALLATION OR USE OF THIS PRODUCT, EXCEPT AS STATED IN THIS LIMITED WARRANTY.
CONDUX WILL IN NO EVENT BE LIABLE FOR INCIDENTAL OR CONSEQUENTIAL DAMAGES.**



Condux International, Inc.

P.O. Box 247 • 145 Kingswood Road, Mankato, MN 56002-0247 USA
1-507-387-6576 • 1-800-533-2077 • FAX 1-507-387-1442
Internet: <http://www.condux.com>

© Copyright 1998, Condux International, Inc
Printed in USA
Literature Part Number: 08920097
Revision Number: 2.00