

Fiber Optic Jamb Skid

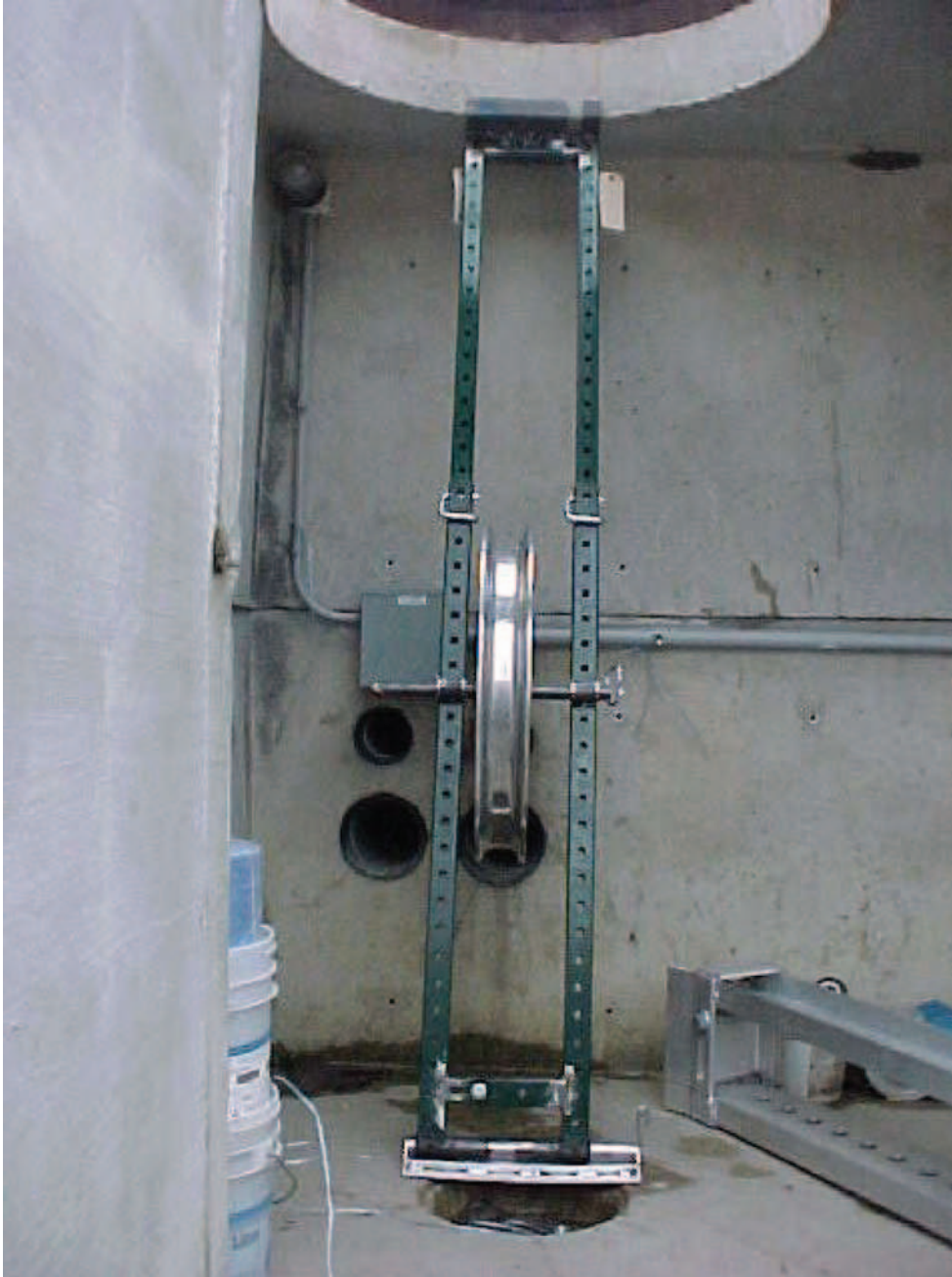

CONDEX

ISO 9001:2008
CERTIFIED

Installation Procedure

NOTE: Before proceeding, ensure that your extension is the correct length (see Table) and that your sheave or quadrant block uses a 1.00" diameter mounting axle.

Part No.	Description	Manhole Height
08097100	46" Base Section	
08097200	43" Extension	49" - 80"

1. Lower the **base section** into the **manhole**.
2. Place the **base section** in line with the **duct**. Fully disengage the **cam-lock foot pedal** and point it towards the **duct** (see Figure 1).
3. Lower the **extension** into the **manhole** and place it over the **base section**.
4. Extend the **extension** at about a **75° angle** until it contacts the manhole's inside edge. Insert the **locking pins** through the **extension** and **base sections** (see Figure 2).
5. Loosen the bolts in the **extension** and **base**. Place the **sheave** at the desired height and insert a axle mounts and axle into the frame of the jamb skid.
6. Push the sides together into their most narrow configuration (see Figure 3), and tighten the bolts in the **extension** and **base**.
7. Align the **Jamb Skid** and the quadrant block or **sheave** wheel with the **duct**. Rotate the **cam-lock foot pedal** about 3/4 of its rotation away from the **duct**.
8. Push down on the **cam-lock foot pedal** until it goes beyond the engaged range and completely locks in place. If necessary, move the base section towards or away from the **duct**.

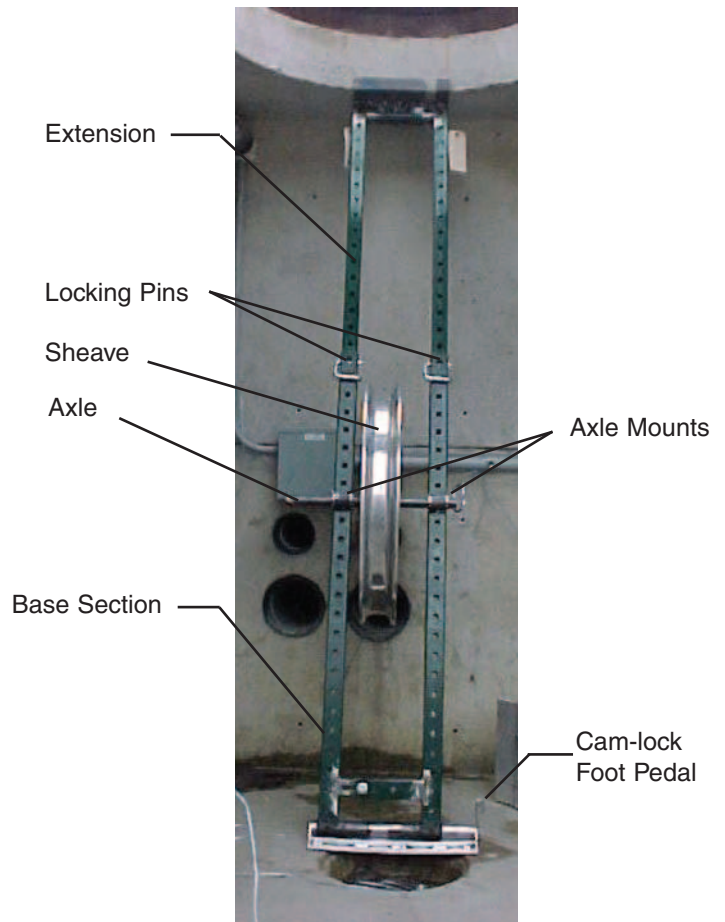

Jamb Skid Components

Removal Procedure

1. Place a leverage bar below the **cam-lock foot pedal** and pry up to release the **Jamb Skid**.
2. Disassemble and remove the **Jamb Skid** by reversing the installation procedures.



!WARNING: Read and understand all procedure and safety instructions before using any Condux Jamb Skid. Failure to do so may result in serious personal injury or death. Save this user's guide for future reference.



!CAUTION: Follow all standard manhole opening procedures, including work area protection and gas detection. Wear personal protective equipment: hard hat, safety glasses, safety shoes, and leather work gloves.



!ADVERTENCIA: Favor de leer y comprender todas las instrucciones de operación y seguridad antes de usar el Condux Jamb Skid. Si Ud. no comprende las instrucciones favor de consultarle a su jefe.



!WARNING: Do not remain in the manhole when pulling cable. During a pulling operation, the Jamb Skid and cable are under tension. Serious personal injury or death may result if a component fails and releases its stored energy.

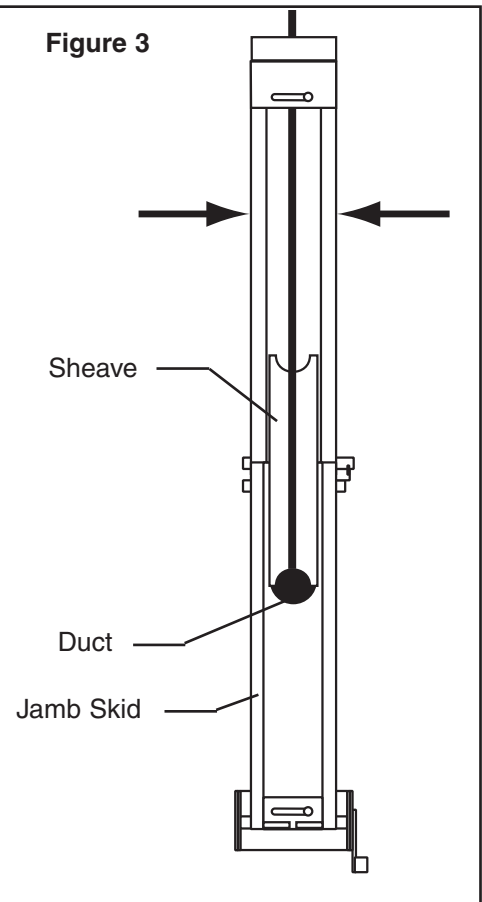
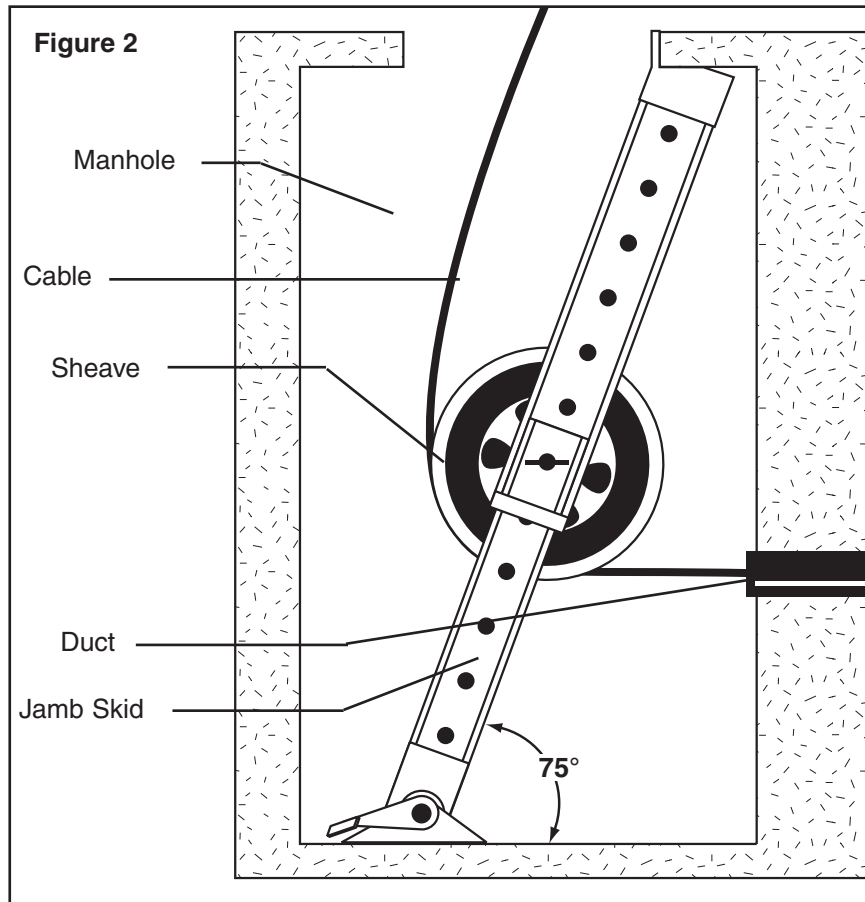
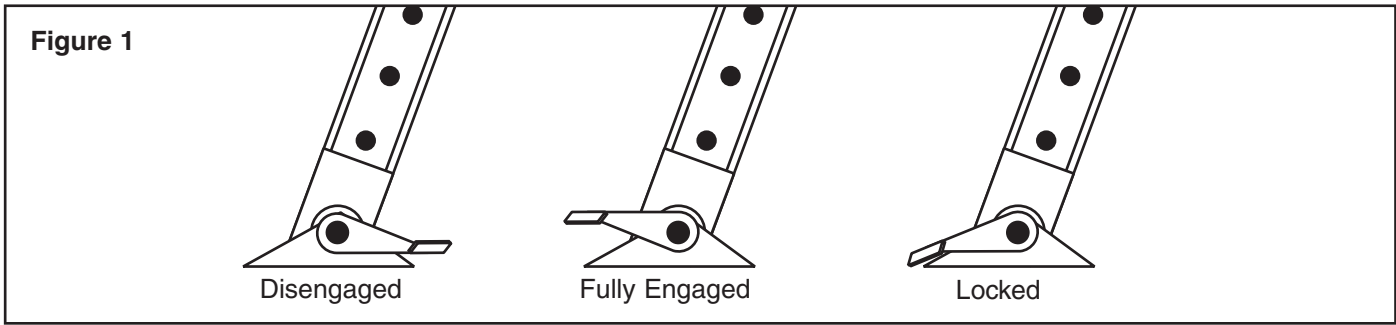

!WARNING: Do not use around live circuits. The aluminum Jamb Skid is highly conductive. Serious personal injury or death may result.



!CAUTION: The Jamb Skid locking pins rotate freely. Do not use the Jamb Skid as a ladder. Personal injury may result.



!WARNING: Ensure the Jamb Skid is properly aligned with the duct and the cam-lock foot pedal is fully locked. Do not exceed 10,000 lbs. of pulling force. Failure to do so may result in personal injury or property damage.



!CAUTION: Do not lower the Jamb Skid sections into the manhole by hand. Personal injury or property damage may result.

Limited Warranty

Condux International, Incorporated extends the following warranty to the original purchaser of these goods for use, subject to the qualifications indicated:

Condux International, Incorporated warrants to the original purchaser for use that the goods or any component thereof manufactured by Condux International will be free from defects in workmanship for a period of one year from the date of purchase, provided such goods are installed, maintained, and used in accordance with Condux's written instructions.

Components not manufactured by Condux International but used within the assembly provided by Condux International are subject to the warranty period as specified by the individual manufacturer of said component, provided such goods are installed, maintained, and used in accordance with Condux's and the original manufacturer's written instructions.

Condux's sole liability and the purchaser's sole remedy for a failure of goods under this limited warranty, and for any and all claims arising out of the purchase and use of the goods, shall be limited to the repair or replacement of the goods that do not conform to this warranty.

To obtain repair or replacement service under the limited warranty, the purchaser must contact the factory for a Return Material Authorization (RMA). Once obtained, send the RMA along with the defective part or goods, transportation prepaid, to: Condux International, Inc.
145 Kingswood Drive
Mankato, MN 56001

THERE ARE NO EXPRESS WARRANTIES COVERING THESE GOODS OTHER THAN AS SET FORTH ABOVE. THE IMPLIED WARRANTIES OR MERCHANTABILITY AND FITNESS FOR A PARTICULAR PURPOSE ARE LIMITED IN DURATION TO ONE YEAR FROM DATE OF PURCHASE.

CONDUX ASSUMES NO LIABILITY IN CONNECTION WITH THE INSTALLATION OR USE OF THIS PRODUCT, EXCEPT AS STATED IN THIS LIMITED WARRANTY. CONDUX WILL IN NO EVENT BE LIABLE FOR INCIDENTAL OR CONSEQUENTIAL DAMAGES.



Condux International, Inc.

P.O. Box 247 • 145 Kingswood Drive, Mankato, MN 56002-0247

507-387-6576 • 800-533-2077 • FAX 507-387-1442

Internet: <http://www.condux.com>

© Copyright 2012, Condux International, Inc.

Printed in USA

Literature Part Number: 08097126

Revision Number: 1.1